

LEIF MEJLBRO

**REAL FUNCTIONS OF SEVERAL VARIABLES -
LINE INT...**

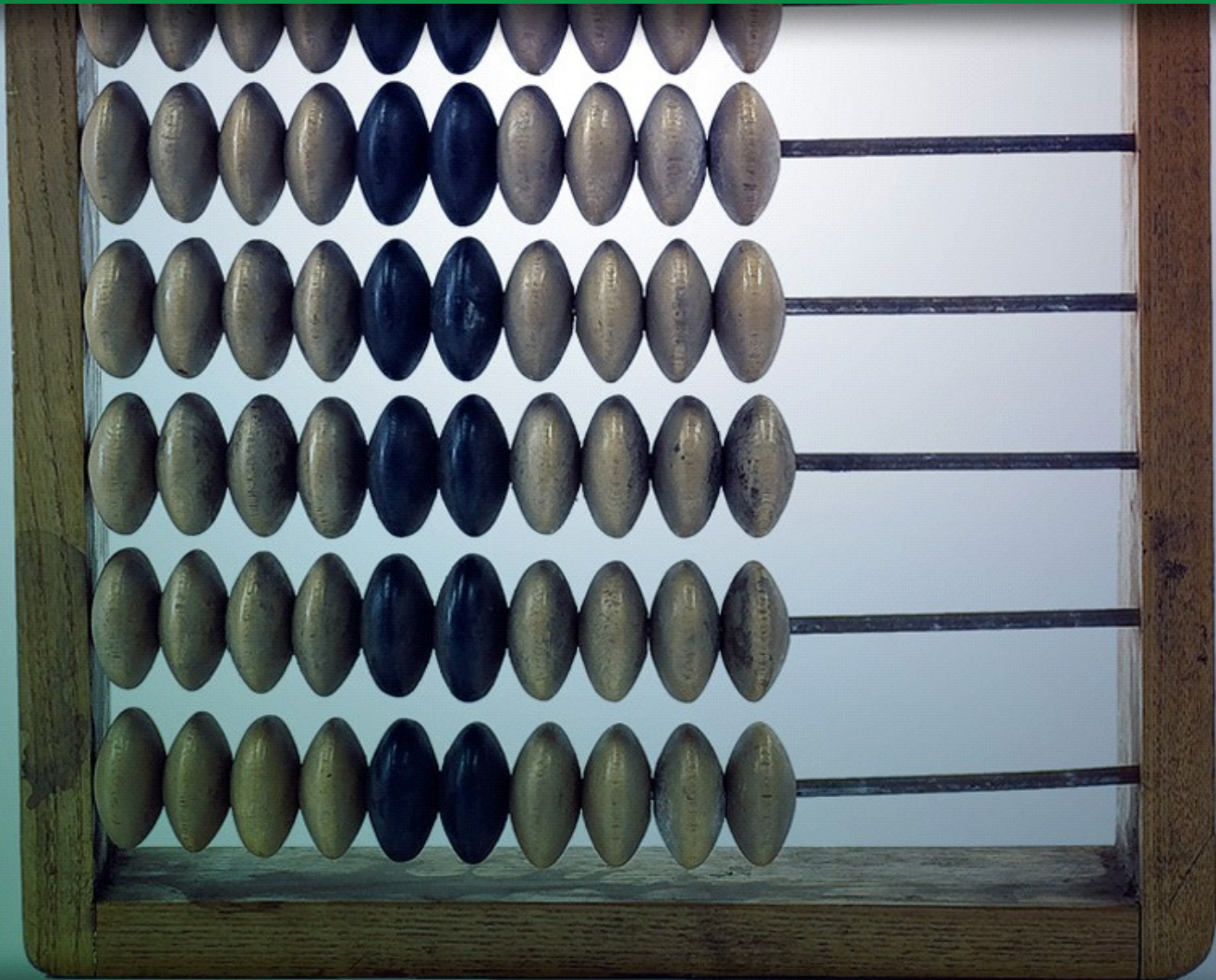

DOWNLOAD FREE TEXTBOOKS AT
BOOKBOON.COM

Leif Mejlbro

Real Functions of Several Variables

Examples of Line Integrales

Calculus 2c-7

Real Functions of Several Variables – Examples of Line Integrales – Calculus 2c-7
© 2007 Leif Mejlbro & Ventus Publishing Aps
ISBN 978-87-7681-258-4

Contents

	Preface	5
1	Line integrals, rectangular coordinates	6
2	Line integral, polar coordinates	25
3	Arc lengths and parametric descriptions by the arc length	32
4	Tangential line integrals	57

Please click the advert

WHAT'S MISSING IN THIS EQUATION?

You could be one of our future talents

MAERSK INTERNATIONAL TECHNOLOGY & SCIENCE PROGRAMME

Are you about to graduate as an **engineer** or **geoscientist**? Or have you already graduated?
If so, there may be an exciting future for you with A.P. Moller - Maersk.



MAERSK

www.maersk.com/mitas

Preface

In this volume I present some examples of *line integrals*, cf. also *Calculus 2b, Functions of Several Variables*. Since my aim also has been to demonstrate some solution strategy I have as far as possible structured the examples according to the following form

A *Awareness*, i.e. a short description of what is the problem.

D *Decision*, i.e. a reflection over what should be done with the problem.

I *Implementation*, i.e. where all the calculations are made.

C *Control*, i.e. a test of the result.

This is an ideal form of a general procedure of solution. It can be used in any situation and it is not linked to Mathematics alone. I learned it many years ago in the Theory of Telecommunication in a situation which did not contain Mathematics at all. The student is recommended to use it also in other disciplines.

One is used to from high school immediately to proceed to **I. Implementation**. However, examples and problems at university level are often so complicated that it in general will be a good investment also to spend some time on the first two points above in order to be absolutely certain of what to do in a particular case. Note that the first three points, **ADI**, can always be performed.

This is unfortunately not the case with **C Control**, because it from now on may be difficult, if possible, to check one's solution. It is only an extra securing whenever it is possible, but we cannot include it always in our solution form above.

I shall on purpose not use the logical signs. These should in general be avoided in Calculus as a shorthand, because they are often (too often, I would say) misused. Instead of \wedge I shall either write "and", or a comma, and instead of \vee I shall write "or". The arrows \Rightarrow and \Leftrightarrow are in particular misunderstood by the students, so they should be totally avoided. Instead, write in a plain language what you mean or want to do.

It is my hope that these examples, of which many are treated in more ways to show that the solutions procedures are not unique, may be of some inspiration for the students who have just started their studies at the universities.

Finally, even if I have tried to write as careful as possible, I doubt that all errors have been removed. I hope that the reader will forgive me the unavoidable errors.

Leif Mejlbro
14th October 2007

1 Line integrals, rectangular coordinates

Example 1.1 Calculate in each of the following cases the given line integral, where the curve \mathcal{K} is given by the parametric description

$$\mathcal{K} = \{\mathbf{x} \in \mathbb{R}^k \mid \mathbf{x} = \mathbf{r}(t), \quad t \in I\}, \quad k = 2 \text{ or } k = 3.$$

1) The line integral $\int_{\mathcal{K}} ds$, where

$$\mathbf{r}(t) = (a(1 - \cos t), a(t - \sin t)), \quad t \in [0, 4\pi].$$

2) The line integral $\int_{\mathcal{K}} \sqrt{x} ds$, where

$$\mathbf{r}(t) = (a(1 - \cos t), a(t - \sin t)), \quad t \in [0, 4\pi].$$

3) The line integral $\int_{\mathcal{K}} z ds$, where

$$\mathbf{r}(t) = (t, 3t^2, 6t^3), \quad t \in [0, 2].$$

4) The line integral $\int_{\mathcal{K}} \frac{1}{1 + 6y} ds$, where

$$\mathbf{r}(t) = (t, 3t^2, 6t^3), \quad t \in [0, 2].$$

5) The line integral $\int_{\mathcal{K}} (x + e^z)$, where

$$\mathbf{r}(t) = (\cos t, \sin t, \ln \cos t), \quad t \in \left[0, \frac{\pi}{4}\right].$$

[Cf. **Example 3.3.6.**]

6) The line integral $\int_{\mathcal{K}} (x^2 + y^2 + z^2) ds$, where

$$\mathbf{r}(t) = (e^t \cos t, e^t \sin t, e^t), \quad t \in [0, 2].$$

7) The line integral $\int_{\mathcal{K}} \frac{x + y}{z^2} ds$, where

$$\mathbf{r}(t) = \frac{1}{\sqrt{3}} (e^t, e^t \sin t, e^t), \quad t \in [0, u].$$

[Cf. **Example 3.3.7.**]

8) The line integral $\int_{\mathcal{K}} (x^2 + y^2) ds$, where

$$\mathbf{r}(t) = \left(\frac{1 - t^2}{1 + t^2}, \frac{2t}{1 + t^2} \right), \quad t \in \mathbb{R}.$$

9) The line integral $\int_{\mathcal{K}} ds$, where

$$\mathbf{r}(t) = \left(2 \operatorname{Arccsin} t, \ln(1 - t^2), \ln \frac{1 + t}{1 - t} \right), \quad t \in \left[0, \frac{1}{\sqrt{2}}\right].$$

10) The line integral $\int_{\mathcal{K}} xe^y ds$, where

$$\mathbf{r}(t) = \left(2 \operatorname{Arccsin} t, \ln(1 - t^2), \ln \frac{1+t}{1-t} \right), \quad t \in \left[0, \frac{1}{\sqrt{2}} \right].$$

11) The line integral $\int_{\mathcal{K}} \frac{1}{\sqrt{1+3x^2+z^2}} ds$, where

$$\mathbf{r}(t) = (\cos t, 2 \sin t, e^t), \quad t \in [-1, 1].$$

A Line integrals.

D First find $\|\mathbf{r}'(t)\|$ in each case. Then compute the line integral.

Please click the advert



CHALLENGE YOURSELF

WWW.STUDYINSWEDEN.SE

Today's job market values ambitious, innovative, perceptive team players. Swedish universities foster these qualities through a forward-thinking culture where you're close to the latest ideas and global trends.

Si.
Swedish Institute

Whatever your career goals may be, studying in Sweden will give you valuable skills and a competitive advantage for your future. www.studyinsweden.se

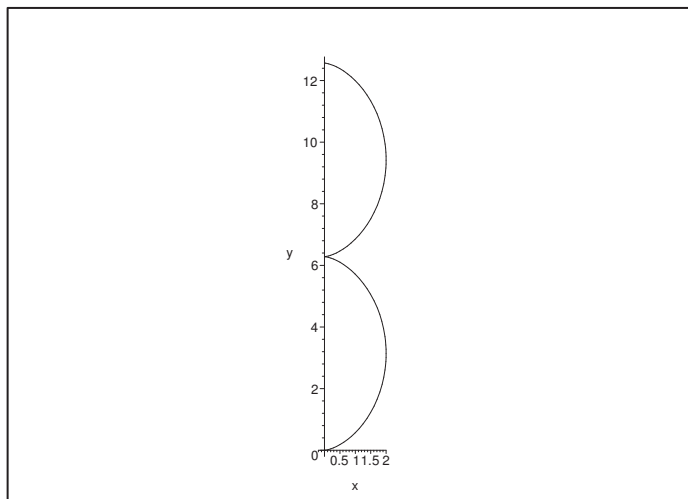

Figure 1: The plane curve \mathcal{K} of **Example 1.1.1** and **Example 1.1.2** for $a = 1$.

I 1) Here,

$$\mathbf{r}'(t) = a(\sin t, 1 - \cos t),$$

so

$$\|\mathbf{r}'(t)\| = a\sqrt{\sin^2 t + (1 - \cos t)^2} = a\sqrt{2 - 2\cos t} = a\sqrt{4\sin^2 \frac{t}{2}} = 2a \left| \sin \frac{t}{2} \right|.$$

Then accordingly,

$$\int_{\mathcal{K}} ds = \int_0^{4\pi} 2a \left| \sin \frac{t}{2} \right| dt = 4a \int_0^{2\pi} |\sin u| du = 8a \int_0^{\pi} \sin u du = 16a.$$

2) It follows from 1) that

$$\|\mathbf{r}'(t)\| = a\sqrt{2(1 - \cos t)},$$

thus

$$\begin{aligned} \int_{\mathcal{K}} \sqrt{x} ds &= \int_0^{4\pi} \sqrt{a(1 - \cos t)} \cdot a\sqrt{2(1 - \cos t)} dt \\ &= a\sqrt{2a} \int_0^{4\pi} |1 - \cos t| dt = a\sqrt{2a} \int_0^{4\pi} (1 - \cos t) dt = 4\sqrt{2} \pi a\sqrt{a}. \end{aligned}$$

3) It follows from $\mathbf{r}'(t) = (1, 6t, 18t^2)$ that

$$\|\mathbf{r}'(t)\| = \sqrt{1 + 36t^2 + 324t^4} = \sqrt{(1 + 18t^2)^2} = 1 + 18t^2,$$

hence

$$\int_{\mathcal{K}} z ds = \int_0^2 6t^3(1 + 18t^2) dt = \left[\frac{6}{4} t^4 + \frac{6 \cdot 18}{6} t^6 \right]_0^2 = \frac{3}{2} \cdot 16 + 18 \cdot 64 = 24 + 1152 = 1176.$$

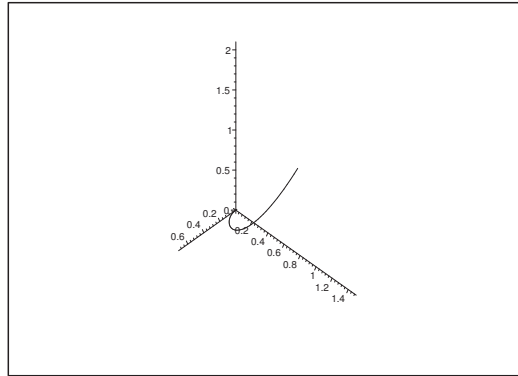

Figure 2: The curve \mathcal{K} for $t \in [0, \frac{7}{10}]$. It is used in **Example 1.1.3** and **Example 1.1.4** for $t \in [0, 2]$.

4) It follows from 3 above that $\|\mathbf{r}'(t)\| = 1 + 18t^2$, so

$$\int_{\mathcal{K}} \frac{1}{1+6y} ds = \int_0^2 \frac{1+18t^2}{1+18t^2} dt = 2.$$

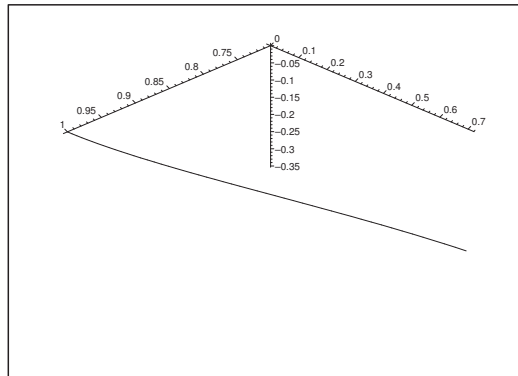

Figure 3: The curve \mathcal{K} of **Example 1.1.5**.

5) It follows from

$$\mathbf{r}'(t) = \left(-\sin t, \cos t, -\frac{\sin t}{\cos t} \right),$$

that

$$\|\mathbf{r}'(t)\| = \sqrt{\sin^2 t + \cos^2 t + \frac{\sin^2 t}{\cos^2 t}} = \sqrt{1 + \frac{\sin^2 t}{\cos^2 t}} = \frac{1}{|\cos t|},$$

hence

$$\int_{\mathcal{K}} (x + e^z) ds = \int_0^{\frac{\pi}{4}} (\cos t + e^{\ln \cos t}) \frac{1}{\cos t} dt = \int_0^{\frac{\pi}{4}} 2 dt = \frac{\pi}{2}.$$

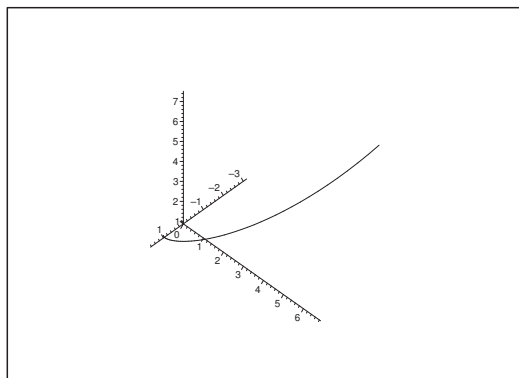

Figure 4: The curve \mathcal{K} of **Example 1.1.6** and – apart from e factor $1/\sqrt{3}$ – of **Example 1.1.7**.

6) It follows from

$$\mathbf{r}'(t) = (e^t(\cos t - \sin t), e^t(\sin t + \cos t), e^t),$$

that

$$\|\mathbf{r}'(t)\| = e^t \sqrt{(\cos t - \sin t)^2 + (\sin t + \cos t)^2 + 1} = \sqrt{3} e^t,$$

thus

$$\begin{aligned} \int_{\mathcal{K}} (x^2 + y^2 + z^2) ds &= \int_0^2 e^{2t} (\cos^2 t + \sin^2 t + 1) \cdot \sqrt{3} e^t dt \\ &= 2\sqrt{3} \int_0^2 e^{3t} dt = \frac{2\sqrt{3}}{3} (e^6 - 1). \end{aligned}$$

7) If we first divide by $\sqrt{3}$, we get by **Example 1.1.6** the more nice expression $\|\mathbf{r}'(t)\| = e^t$. Then the line integral becomes

$$\int_{\mathcal{K}} ds = \int_0^u e^t dt = e^u - 1.$$

8) We get by just computing

$$\begin{aligned} \mathbf{r}'(t) &= \left(\frac{-2t(1+t^2) - 2t(1-t^2)}{(1+t^2)^2}, \frac{2(1+t^2) - 2t \cdot 2t}{(1+t^2)^2} \right) \\ &= \left(-\frac{4t}{(1+t^2)^2}, \frac{2(1-t^2)}{(1+t^2)^2} \right) = \frac{1}{(1+t^2)^2} (-2t, 1-t^2), \end{aligned}$$

hence

$$\|\mathbf{r}'(t)\| = \frac{1}{(1+t^2)^2} \sqrt{4t^2 + (1-t^2)^2} = \frac{1}{(1+t^2)^2} \sqrt{(1+t^2)^2} = \frac{1}{1+t^2}.$$

Then finally,

$$\begin{aligned} \int_{\mathcal{K}} (x^2 + y^2) ds &= \int_{-\infty}^{+\infty} \frac{1}{(1+t^2)^2} \{(1-t^2)^2 + 4t^2\} \cdot \frac{2}{1+t^2} dt \\ &= \int_{-\infty}^{+\infty} \frac{(1+t^2)^2}{(1+t^2)^2} \cdot \frac{2}{1+t^2} dt = [2 \operatorname{Arctan} t]_{-\infty}^{+\infty} = 2\pi. \end{aligned}$$

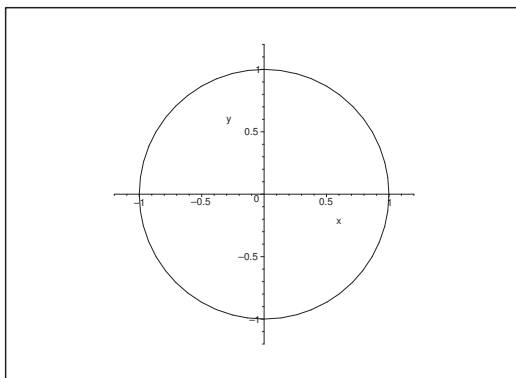

Figure 5: The curve \mathcal{K} of **Example 1.1.8**, i.e. a circle except for the point $(-1, 0)$.

ALTERNATIVE. The computation above was a little elaborated. However, the line integral is independent of the chosen parametric description, and \mathcal{K} is a circle with the exception of the point $(-1, 0)$, which is of no importance for the integration. Therefore, we can apply the simpler parametric description

$$\mathbf{r}(t) = (\cos t, \sin t), \quad t \in]-\pi, \pi[,$$

where

$$\mathbf{r}'(t) = (-\sin t, \cos t) \quad \text{og} \quad \|\mathbf{r}'(t)\| = \sqrt{\sin^2 t + \cos^2 t} = 1.$$

Then the line integral becomes almost trivial,

$$\int_{\mathcal{K}} (x^2 + y^2) ds = \int_{-\pi}^{\pi} 1^2 dt = 2\pi.$$

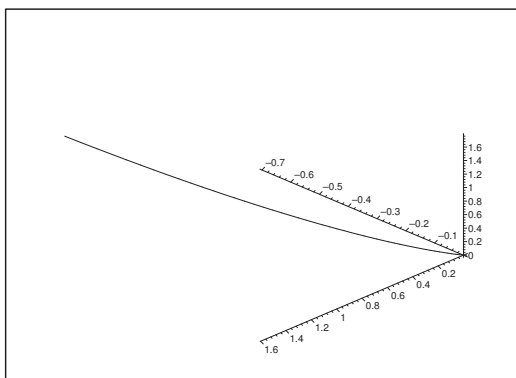

Figure 6: The curve \mathcal{K} of **Example 1.1.9** and **Example 1.1.10**.

9) Here

$$\mathbf{r}'(t) = \left(\frac{2}{\sqrt{1-t^2}}, -\frac{2t}{1-t^2}, \frac{1}{1+t} + \frac{1}{1-t} \right) = \frac{2}{1-t^2} \left(\sqrt{1-t^2}, -t, 1 \right),$$

hence

$$\|\mathbf{r}'(t)\| = \frac{2}{1-t^2} \sqrt{1-t^2+t^2+1} = \frac{2\sqrt{2}}{1-t^2} = \sqrt{2} \left(\frac{1}{1+t} - \frac{1}{t-1} \right).$$

The line integral is

$$\begin{aligned} \int_{\mathcal{K}} ds &= \int_0^{\frac{1}{\sqrt{2}}} \sqrt{2} \left(\frac{1}{1+t} - \frac{1}{t-1} \right) dt = \sqrt{2} \left[\ln \frac{1-t}{1+t} \right]_0^{\frac{1}{\sqrt{2}}} \\ &= \sqrt{2} \ln \left(\frac{1+\frac{1}{\sqrt{2}}}{1-\frac{1}{\sqrt{2}}} \right) = \sqrt{2} \ln \left(\frac{\sqrt{2}+1}{\sqrt{2}-1} \right) = 2\sqrt{2} \ln(\sqrt{2}+1). \end{aligned}$$

10) We consider the same curve as in **Example 1.1.9**, so we can reuse that

$$\|\mathbf{r}'(t)\| = \frac{2\sqrt{2}}{1-t^2} = \sqrt{2} \left(\frac{1}{1+t} - \frac{1}{t-1} \right), \quad t \in \left[0, \frac{1}{\sqrt{2}} \right],$$

Please click the advert

The advertisement features a collage of four images. The top-left image shows a person sitting at a desk with multiple computer monitors, working in an office. The top-right image shows two women in professional attire; one is holding a laptop and they appear to be in a discussion. The bottom-left image shows a man in a dark suit holding a white folder or document, standing in an office. The bottom-right image shows a modern, multi-story building at night with its lights on. The entire advertisement is set against a dark blue background with a light blue wavy graphic at the bottom. The Oticon logo is in the bottom right corner.

www.job.oticon.dk

oticon
PEOPLE FIRST

Download free books at BookBooN.com

and the line integral becomes

$$\begin{aligned} \int_{\mathcal{K}} x e^y ds &= \int_0^{\frac{1}{\sqrt{2}}} 2 \operatorname{Arccsin} t \cdot (1-t^2) \cdot \frac{2\sqrt{2}}{1-t^2} dt = 4\sqrt{2} \int_0^{\frac{1}{\sqrt{2}}} \operatorname{Arccsin} t dt \\ &= 4\sqrt{2} \int_0^{\frac{\pi}{4}} u \cos u du = 4\sqrt{2} [u \sin u + \cos u]_0^{\frac{\pi}{4}} = 4\sqrt{2} \left\{ \frac{\pi}{4} \cdot \frac{1}{\sqrt{2}} + \frac{1}{\sqrt{2}} - 1 \right\} \\ &= 4 + \pi - 4\sqrt{2} = \pi - 4(\sqrt{2} - 1). \end{aligned}$$

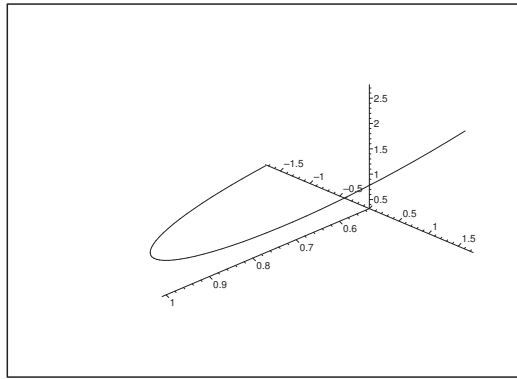

Figure 7: The curve \mathcal{K} of **Example 1.1.11**.

11) Here

$$\mathbf{r}'(t) = (-\sin t, 2 \cos t, e^t),$$

so

$$\|\mathbf{r}'(t)\| = \sqrt{\sin^2 t + 4 \cos^2 t + e^{2t}} = \sqrt{1 + 3 \cos^2 t + e^{2t}}.$$

The parametric description of the integrand restricted to the curve is

$$\sqrt{1 + 3x^2 + z^2} = \sqrt{1 + 3 \cos^2 t + e^{2t}},$$

so the line integral becomes easy to compute

$$\int_{\mathcal{K}} \frac{1}{\sqrt{1 + 3x^2 + z^2}} ds = \int_{-1}^1 \frac{1}{\sqrt{1 + 3 \cos^2 t + e^{2t}}} \sqrt{1 + 3 \cos^2 t + e^{2t}} dt = \int_{-1}^1 1 dt = 2.$$

Example 1.2 Calculate in each of the following cases the given line integral along the given plane curve \mathcal{K} of the equation $y = Y(x)$, $x \in I$.

1) The line integral $\int_{\mathcal{K}} x^2 ds$ along the curve

$$y = Y(x) = \ln x, \quad x \in [1, 2\sqrt{2}].$$

2) The line integral $\int_{\mathcal{K}} \frac{1}{1+4y} ds$ along the curve

$$y = Y(x) = x^2, \quad x \in [0, 1].$$

3) The line integral $\int_{\mathcal{K}} y^2 ds$ along the curve

$$y = Y(x) = x, \quad x \in [1, 2].$$

4) The line integral $\int_{\mathcal{K}} \frac{1}{\sqrt{2-y^2}} ds$ along the curve

$$y = Y(x) = \sin x, \quad x \in [0, \pi].$$

5) The line integral $\int_{\mathcal{K}} \frac{1}{\sqrt{2+y^2}} ds$ along the curve

$$y = Y(x) = \sinh x, \quad x \in [0, 2].$$

6) The line integral $\int_{\mathcal{K}} y e^x ds$ along the curve

$$y = Y(x) = e^x, \quad x \in [0, 1].$$

A Line integrals along plane curves.

D Sketch if possible the den plane curve. Compute the weight function $\sqrt{1+Y'(x)^2}$ and finally reduce the line integral to an ordinary integral.

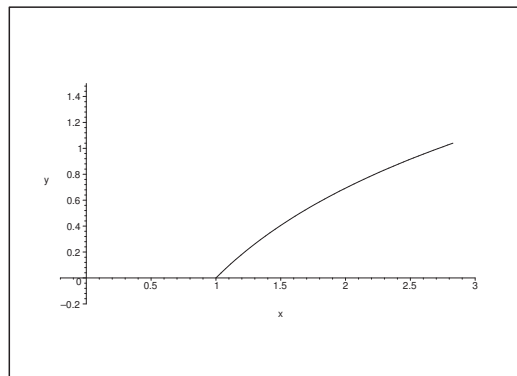

Figure 8: The curve \mathcal{K} of **Example 1.2.1**.

I 1) It follows from $Y'(x) = \frac{1}{x}$ that

$$\sqrt{1+Y'(x)^2} = \frac{1}{x} \sqrt{1+x^2}, \quad x \in [1, 2\sqrt{2}].$$

Thus we get the line integral

$$\begin{aligned}\int_{\mathcal{K}} x^2 ds &= \int_1^{2\sqrt{2}} x^2 \cdot \frac{1}{x^2} \sqrt{1+x^2} dx = \int_0^{2\sqrt{2}} \sqrt{1+x^2} \cdot x dx \\ &= \left[\frac{1}{2} \cdot \frac{2}{3} (1+x^2)^{\frac{3}{2}} \right]_1^{2\sqrt{2}} = \frac{1}{3} \{ 9^{\frac{3}{2}} - 2^{\frac{3}{2}} \} = \frac{1}{3} (27 - 2\sqrt{2}) = 9 - \frac{2}{3} \sqrt{2}.\end{aligned}$$

Please click the advert

CHALLENGE YOURSELF

WWW.STUDYINSWEDEN.SE

Si.
Swedish Institute

Today's job market values ambitious, innovative, perceptive team players. Swedish universities foster these qualities through a forward-thinking culture where you're close to the latest ideas and global trends.

Whatever your career goals may be, studying in Sweden will give you valuable skills and a competitive advantage for your future. www.studyinsweden.se

Download free books at BookBooN.com

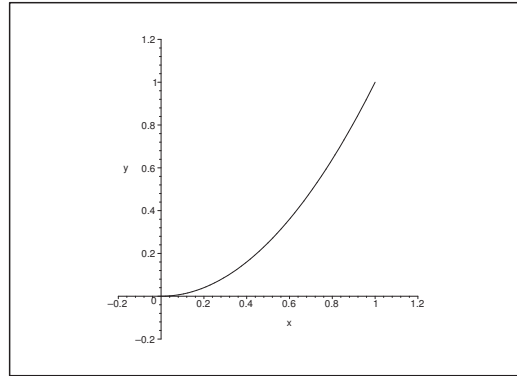
Figure 9: The curve \mathcal{K} of **Example 1.2.2**.

2) From $Y'(x) = 2x$ follows that

$$\sqrt{1 + Y'(x)^2} = \sqrt{1 + 4x^2},$$

and thus

$$\begin{aligned} \int_{\mathcal{K}} \frac{1}{1+4y} ds &= \int_0^1 \frac{\sqrt{1+4x^2}}{1+4x^2} dx = \int_0^1 \frac{1}{\sqrt{1+(2x)^2}} dx = \frac{1}{2} \int_0^2 \frac{1}{\sqrt{1+t^2}} dt \\ &= \frac{1}{2} \left[\ln(t + \sqrt{1+t^2}) \right]_0^2 = \frac{1}{2} \ln\left(\frac{2+\sqrt{5}}{1}\right) = \frac{1}{2} \ln(2+\sqrt{5}). \end{aligned}$$

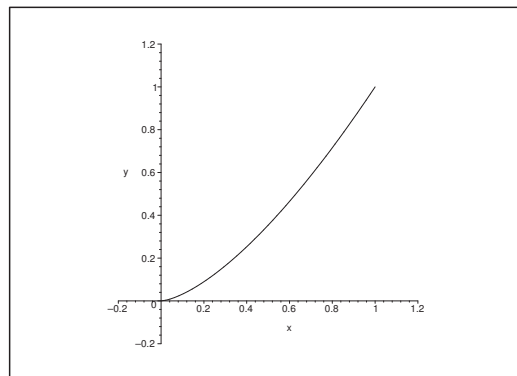
Figure 10: The curve \mathcal{K} of **Example 1.2.3**.

3) Here clearly $\sqrt{1 + Y'(x)^2} = \sqrt{1 + 1^2} = \sqrt{2}$, so

$$\int_{\mathcal{K}} y^2 ds = \int_1^2 x^2 \sqrt{2} ds = \frac{\sqrt{2}}{3} [x^3]_1^2 = \frac{7}{3} \sqrt{2}.$$

4) We get by differentiation of $Y(x) = \sin x$ that $Y'(x) = \cos x$, hence the weight function is

$$\sqrt{1 + Y'(x)^2} = \sqrt{1 + \cos^2 x} = \sqrt{2 - \sin^2 x}.$$

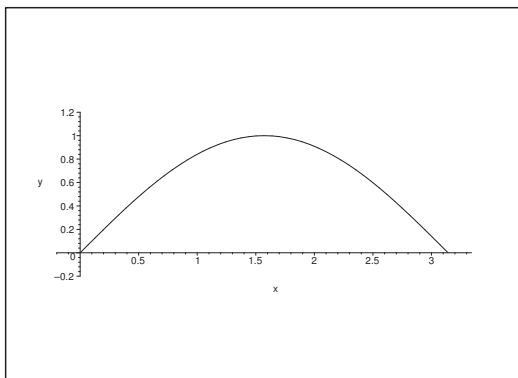
Figure 11: The curve \mathcal{K} of **Example 1.2.4**.

We finally get the line integral by insertion

$$\int_{\mathcal{K}} \frac{1}{\sqrt{2-y^2}} ds = \int_0^{\pi} \frac{1}{\sqrt{2-\sin^2 x}} \sqrt{2-\sin^2 x} dx = \int_0^{\pi} dx = \pi.$$

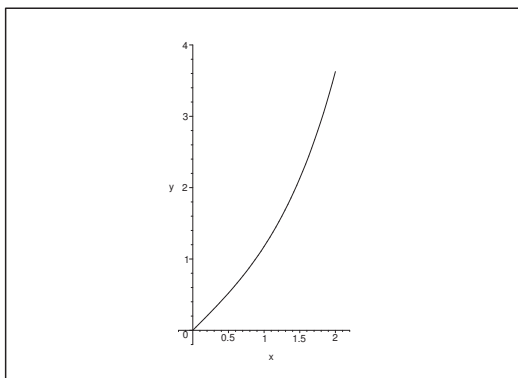
Figure 12: The curve \mathcal{K} of **Example 1.2.5**.

- 5) When $Y(x) = \sinh x$, then $Y'(x) = \cosh x$, and the weight becomes

$$\sqrt{1+Y'(x)^2} = \sqrt{1+\cosh^2 x} = \sqrt{2+\sinh^2 x}.$$

We get finally the line integral by insertion

$$\int_{\mathcal{K}} \frac{1}{\sqrt{2+y^2}} ds = \int_0^2 \frac{1}{\sqrt{2+\sinh^2 x}} \sqrt{2+\sinh^2 x} dx = \int_0^2 dx = 2.$$

- 6) When $Y(x) = e^x$ then also $Y'(x) = e^x$, so the weight function becomes

$$\sqrt{1+Y'(x)^2} = \sqrt{1+e^{2x}}.$$

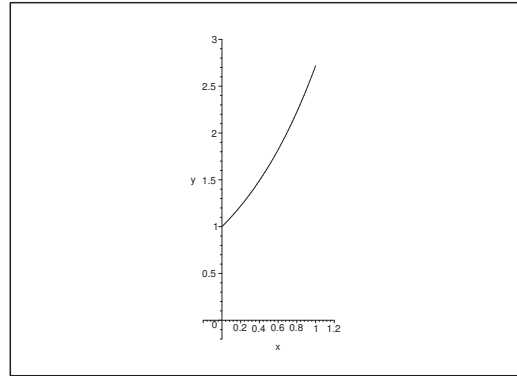
Figure 13: The curve \mathcal{K} of **Example 1.2.6**.

We get the line integral by insertion

$$\begin{aligned} \int_{\mathcal{K}} ye^x ds &= \int_0^1 e^x \cdot e^x \cdot \sqrt{1+e^{2x}} dx = \int_0^1 \sqrt{1+e^{2x}} \cdot e^{2x} dx \\ &= \frac{1}{2} \int_{x=0}^1 \sqrt{1+e^{2x}} d(1+e^{2x}) = \frac{1}{2} \cdot \frac{2}{3} \left[(1+e^{2x})^{\frac{3}{2}} \right]_0^1 = \frac{1}{3} \left\{ (1+e^2)^{\frac{3}{2}} - 1 \right\}. \end{aligned}$$

Please click the advert

Turning a challenge into a learning curve. Just another day at the office for a high performer.

Accenture Boot Camp – your toughest test yet

Choose Accenture for a career where the variety of opportunities and challenges allows you to make a difference every day. A place where you can develop your potential and grow professionally, working alongside talented colleagues. The only place where you can learn from our unrivalled experience, while helping our global clients achieve high performance. If this is your idea of a typical working day, then Accenture is the place to be.

It all starts at Boot Camp. It's 48 hours that will stimulate your mind and enhance your career prospects. You'll spend time with other students, top Accenture Consultants and special guests. An inspirational two days

packed with intellectual challenges and activities designed to let you discover what it really means to be a high performer in business. We can't tell you everything about Boot Camp, but expect a fast-paced, exhilarating

and intense learning experience. It could be your toughest test yet, which is exactly what will make it your biggest opportunity.

Find out more and apply online.

Visit accenture.com/bootcamp

• Consulting • Technology • Outsourcing

High performance. Delivered.

Example 1.3 A space curve \mathcal{K} is given by the parametric description

$$\mathbf{r}(t) = (e^t, t\sqrt{2}, e^{-t}), \quad t \in [0, \ln 3].$$

Prove that the curve element ds is given by $(e^t + e^{-t}) dt$, and then find the line integral

$$\int_{\mathcal{K}} x^3 z ds.$$

A Curve element and line integral.

D Follow the guidelines.

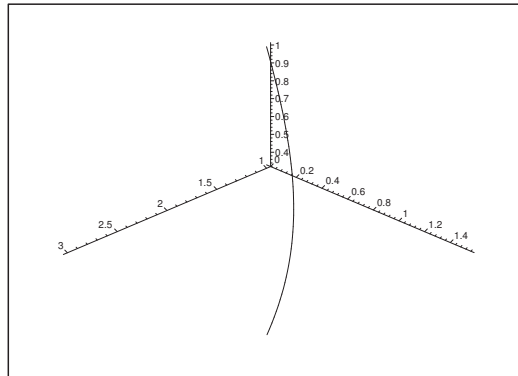

Figure 14: The curve \mathcal{K} .

I The curve is clearly of class C^∞ . Furthermore,

$$\|\mathbf{r}'(t)\|^2 = (e^t)^2 + (\sqrt{2})^2 + (e^{-t})^2 = e^{2t} + 2 + e^{-2t} = (e^t + e^{-t})^2,$$

and we get the curve element

$$ds = \|\mathbf{r}'(t)\| dt = (e^t + e^{-t}) dt$$

with respect to the given parametric description.

Then compute the line integral,

$$\begin{aligned} \int_{\mathcal{K}} x^3 z ds &= \int_0^{\ln 3} e^{3t} e^{-t} (e^t + e^{-t}) dt = \int_0^{\ln 3} (e^{3t} + e^t) dt \\ &= \left[\frac{1}{3} e^{3t} + e^t \right]_0^{\ln 3} = \frac{1}{3} \cdot 3^3 + 3 - \frac{1}{3} - 1 = \frac{32}{3}, \end{aligned}$$

where we alternatively first can apply the change of variables $u = e^t$, from which

$$\int_{\mathcal{K}} x^3 z ds = \int_1^3 (u^2 + 1) du = \left[\frac{1}{3} u^3 + u \right]_1^3 = 9 + 3 - \frac{1}{3} - 1 = \frac{32}{3}.$$

Example 1.4 A space curve \mathcal{K} is given by the parametric description

$$\mathbf{r}(t) = \left(t + 4 \cos t, \frac{4}{3}t - 3 \cos t, 5 \sin t \right), \quad t \in \left[0, \frac{\pi}{2} \right].$$

Find the value of the line integral

$$\int_{\mathcal{K}} x \, ds.$$

A Line integral.

D First find the curve element $ds = \|\mathbf{r}'(t)\| \, dt$.

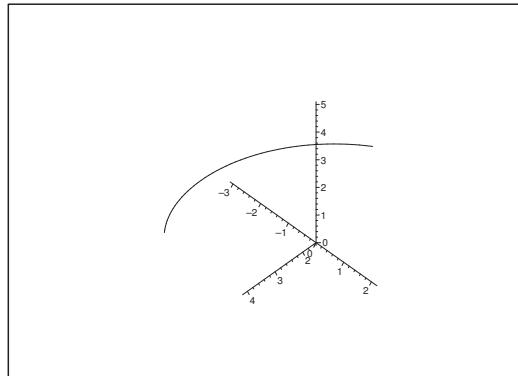

Figure 15: The space curve \mathcal{K} .

I From

$$\mathbf{r}'(t) = \left(1 - 4 \sin t, \frac{4}{3} + 3 \sin t, 5 \cos t \right),$$

follows that

$$\begin{aligned} \|\mathbf{r}'(t)\|^2 &= (1 - 4 \sin t)^2 + \left(\frac{4}{3} + 3 \sin t \right)^2 + 25 \cos^2 t \\ &= 1 - 8 \sin t + 16 \sin^2 t + \frac{16}{9} + 8 \sin t + 9 \sin^2 t + 25 \cos^2 t = \frac{25}{9} + 25 = \frac{25}{9} \cdot 10, \end{aligned}$$

thus

$$ds = \|\mathbf{r}'(t)\| \, dt = \frac{5}{3} \sqrt{10} \, dt.$$

The line integral is

$$\begin{aligned} \int_{\mathcal{K}} x \, ds &= \int_0^{\frac{\pi}{2}} (t + 4 \cos t) \cdot \frac{5}{3} \sqrt{10} \, dt = \frac{5}{3} \sqrt{10} \left[\frac{t^2}{2} + 4 \sin t \right]_0^{\frac{\pi}{2}} = \frac{5}{3} \sqrt{10} \left(\frac{\pi^2}{8} + 4 \right) \\ &= \frac{5\pi^2 \sqrt{10}}{24} + \frac{20\sqrt{10}}{3}. \end{aligned}$$

Example 1.5 A space curve \mathcal{K} is given by the parametric description

$$\mathbf{r}(t) = \left(t^2, e^{2t}, \frac{1}{2} t^4 \right), \quad t \in [1, 2].$$

Find the value of the line integral

$$\int_{\mathcal{K}} \frac{1}{\sqrt{x+2xz+y^2}} ds.$$

A Line integral.

D First calculate the weight function $\|\mathbf{r}'(t)\|$.

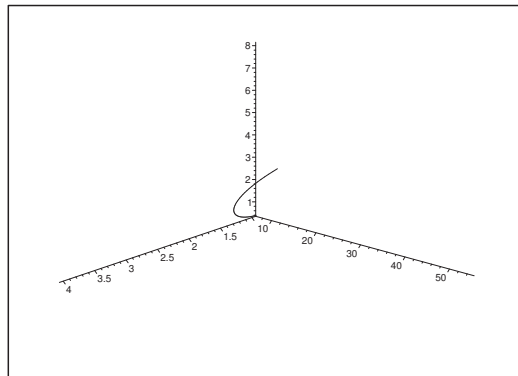

Figure 16: The curve \mathcal{K} . Notice the different scales on the axes.

I We get from

$$\mathbf{r}'(t) = (2t, 2e^{2t}, 2t^3) = 2(t, e^{2t}, t^3)$$

that

$$\|\mathbf{r}'(t)\| = 2\sqrt{e^{4t} + t^2 + t^6}.$$

Then by insertion and reduction,

$$\int_{\mathcal{K}} \frac{1}{\sqrt{x+2xz+y^2}} ds = \int_1^2 \frac{1}{\sqrt{t^2+2t^2 \cdot \frac{1}{2} t^4 + e^{4t}}} \cdot 2\sqrt{e^{4t} + t^2 + t^6} dt = 2.$$

Example 1.6 A space curve \mathcal{K} is given by the parametric description

$$\mathbf{r}(t) = \left(\ln t, t^2, \frac{1}{2} t^4 \right), \quad t \in [1, 2].$$

Prove that the curve element ds is given by $\left(\frac{1}{t} + 2t^3 \right) dt$, and then compute the line integral

$$\int_{\mathcal{K}} \frac{y e^x}{z} ds.$$

A Line integral.

D Follow the guidelines.

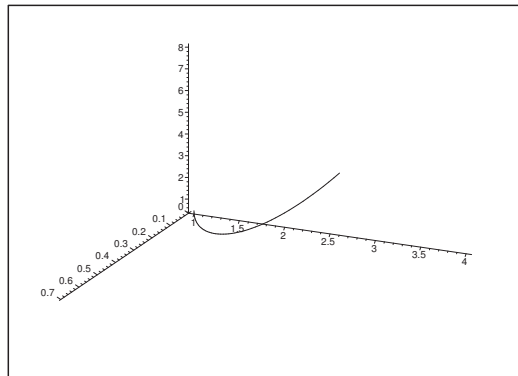

Figure 17: The curve \mathcal{K} .

I Clearly, $\mathbf{r}(t)$ is of class C^∞ for $t \in]1, 2[$. Then

$$\mathbf{r}'(t) = \left(\frac{1}{t}, 2t, 2t^3 \right), \quad t \in]1, 2[,$$

implies that

$$\|\mathbf{r}'(t)\|^2 = \frac{1}{t^2} + 4t^2 + 4t^6 = \left(\frac{1}{t} + 2t^3 \right)^2,$$

so

$$ds = \|\mathbf{r}'(t)\| dt = \left| \frac{1}{t} + 2t^3 \right| dt = \left(\frac{1}{t} + 2t^3 \right) dt \quad \text{for } t \in]1, 2[.$$

We get by insertion of the parametric description,

$$\begin{aligned} \int_{\mathcal{K}} \frac{y e^x}{z} ds &= \int_1^2 \frac{t^2 \cdot t}{\frac{1}{2} t^4} \cdot \left(\frac{1}{t} + 2t^3 \right) dt = 2 \int_1^2 \left(\frac{1}{t^2} + 2t^2 \right) dt \\ &= 2 \left[-\frac{1}{t} + \frac{2}{3} t^3 \right]_1^2 = 2 \left(-\frac{1}{2} + \frac{16}{3} + 1 - \frac{2}{3} \right) = \frac{31}{3}. \end{aligned}$$

Example 1.7 A space curve \mathcal{K} is given by the parametric description

$$\mathbf{r}(t) = (\ln t, t^2, 2t), \quad t \in \left[\frac{1}{2}, \frac{3}{2} \right].$$

- 1) Find a parametric description of the tangent to \mathcal{K} at the point $\mathbf{r}(1)$.
- 2) Prove that the curve element ds is given by $\left(\frac{1}{t} + 2t \right) dt$.
- 3) Compute the value of the line integral

$$\int_{\mathcal{K}} (e^x + \sqrt{y} + 2z) ds.$$

A Space curve; tangent; curve element; line integral.

D Find $\mathbf{r}'(t)$, and apply that $ds = \|\mathbf{r}'(t)\| dt$.

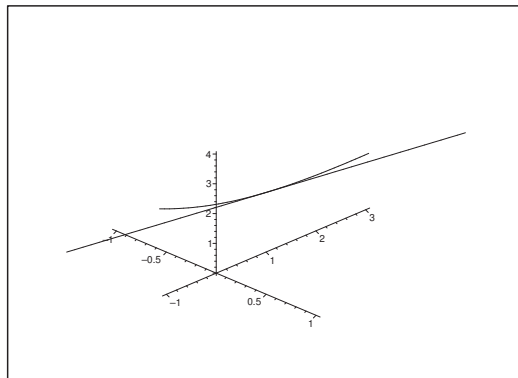

Figure 18: The curve \mathcal{K} and its tangent at $(0, 1, 2)$.

I 1) Since $\mathbf{r}(1) = (\ln 1, 1^2, 2 \cdot 1) = (0, 1, 2)$, and

$$\mathbf{r}'(t) = \left(\frac{1}{t}, 2t, 2 \right), \quad \mathbf{r}'(1) = (1, 2, 2),$$

a parametric description of the tangent is given by

$$(x(u), y(u), z(u)) = (0, 1, 2) + u(1, 2, 2) = (u, 2u + 1, 2u + 2), \quad u \in \mathbb{R}.$$

2) Since

$$\|\mathbf{r}'(t)\|^2 = \frac{1}{t^2} + 4t^2 + 4 = \left(\frac{1}{t} + 2t \right)^2,$$

we get for $t \in \left[\frac{1}{2}, \frac{3}{2} \right]$ that

$$ds = \|\mathbf{r}'(t)\| dt = \left| \frac{1}{t} + 2t \right| dt = \left(\frac{1}{t} + 2t \right) dt.$$

3) Then by insertion and computation we get the line integral

$$\begin{aligned} \int_{\mathcal{K}} (e^x + \sqrt{y} + 2z) \, ds &= \int_{\frac{1}{2}}^{\frac{3}{2}} (e^{\ln t} + \sqrt{t^2} + 2 \cdot 2t) \cdot \left(\frac{1}{t} + 2t\right) \, dt \\ &= \int_{\frac{1}{2}}^{\frac{3}{2}} (t + t + 4t) \cdot \frac{1}{t} (1 + 2t^2) \, dt = 6 \int_{\frac{1}{2}}^{\frac{3}{2}} (1 + 2t^2) \, dt \\ &= [6t + 4t^3]_{\frac{1}{2}}^{\frac{3}{2}} = 6 + 4 \left\{ \left(\frac{3}{2}\right)^3 - \left(\frac{1}{2}\right)^3 \right\} = 6 + \frac{1}{2} (27 - 1) = 19. \end{aligned}$$

Please click the advert



it's an **interesting** world

Get under the skin of it.

Graduate opportunities
Cheltenham | £24,945 + benefits

One of the UK's intelligence services, GCHQ's role is two-fold: to gather and analyse intelligence which helps shape Britain's response to global events, and, to provide technical advice for the protection of Government communication and information systems. In doing so, our specialists – in IT, internet, engineering, languages, information assurance, mathematics and intelligence – get well beneath the surface of global affairs. If you thought the world was an interesting place, you really ought to explore our world of work.

www.careersinbritishintelligence.co.uk

Applicants must be British citizens. GCHQ values diversity and welcomes applicants from all sections of the community. We want our workforce to reflect the diversity of our work.



2 Line integral, polar coordinates

Example 2.1 Compute in each of the following cases the given line integral along the plane curve \mathcal{K} which is given by an equation in polar coordinates.

1) The line integral $\int_{\mathcal{K}} (x^2 + y^2) ds$ along the curve given by

$$\varrho = e^\varphi, \quad \varphi \in [0, 4].$$

2) The line integral $\int_{\mathcal{K}} y ds$ along the curve given by

$$\varrho = a(1 - \cos \varphi), \quad \varphi \in [0, \pi].$$

3) The line integral $\int_{\mathcal{K}} \sqrt{y} ds$ along the curve given by

$$\varphi = \text{Arcsin } \varrho, \quad \varrho \in [0, 1].$$

4) The line integral $\int_{\mathcal{K}} \frac{y}{\sqrt{4a - 3\varrho}} ds$ along the curve given by

$$\varrho = a \cos^2 \varphi, \quad \varphi \in \left[0, \frac{\pi}{2}\right].$$

5) The line integral $\int_{\mathcal{K}} \frac{1}{x^2 + y^2} ds$ along the curve given by

$$\varrho = \frac{a}{\cos \varphi}, \quad \varphi \in \left[0, \frac{\pi}{4}\right].$$

6) The line integral $\int_{\mathcal{K}} (\sqrt{x^2 + y^2} - 1) ds$ along the curve given by

$$\varphi = \varrho - \ln \varrho, \quad \varrho \in [1, 2].$$

7) The line integral $\int_{\mathcal{K}} (x^2 + y^2) ds$ along the curve given by

$$\varphi = \varrho, \quad \varrho \in [1, 2].$$

A Line integral in polar coordinates.

D First compute the weight function $\sqrt{\varrho^2 + \left(\frac{d\varrho}{d\varphi}\right)^2}$ (possibly $\sqrt{1 + \left(\varrho \frac{d\varphi}{d\varrho}\right)^2}$), and then the line integral.

I 1) From $\frac{d\varrho}{d\varphi} = e^\varphi = \varrho$ follows that

$$\sqrt{\varrho^2 + \left(\frac{d\varrho}{d\varphi}\right)^2} = \sqrt{2} \cdot \varrho = \sqrt{2} \cdot e^\varphi,$$

and thus

$$\int_{\mathcal{K}} (x^2 + y^2) ds = \int_0^4 \varrho^2 \sqrt{2} \cdot e^\varphi d\varphi = \sqrt{2} \int_0^4 e^{3\varphi} d\varphi = \frac{\sqrt{2}}{3} (e^{12} - 1).$$

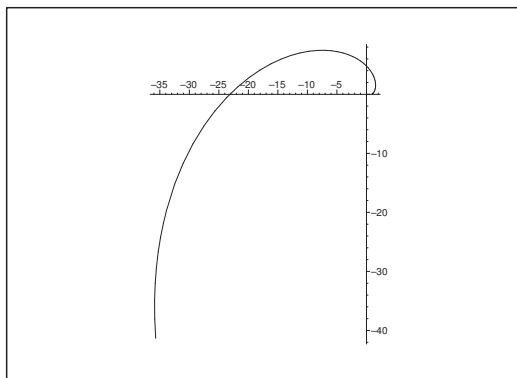

Figure 19: The curve \mathcal{K} of **Example 2.1.1**.

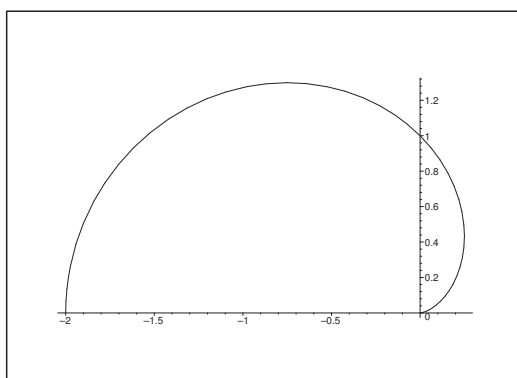
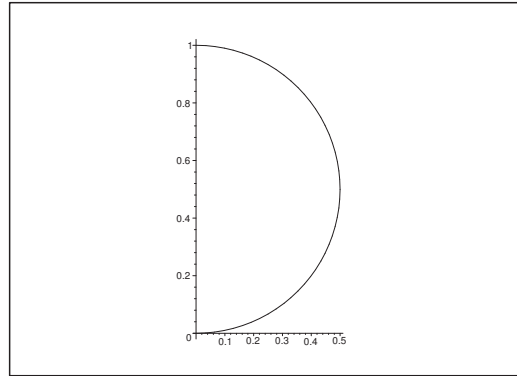

Figure 20: The curve \mathcal{K} of **Example 2.1.2**.

Figure 21: The curve \mathcal{K} of **Example 2.1.3**.

2) From $\frac{d\varrho}{d\varphi} = a \sin \varphi$, follows that

$$\varrho^2 + \left(\frac{d\varrho}{d\varphi} \right)^2 = a^2 \{ (1 - \cos \varphi)^2 + \sin^2 \varphi \} = a^2 \cdot 2(1 - \cos \varphi),$$

Please click the advert

Brain power



By 2020, wind could provide one-tenth of our planet's electricity needs. Already today, SKF's innovative know-how is crucial to running a large proportion of the world's wind turbines.

Up to 25 % of the generating costs relate to maintenance. These can be reduced dramatically thanks to our systems for on-line condition monitoring and automatic lubrication. We help make it more economical to create cleaner, cheaper energy out of thin air.

By sharing our experience, expertise, and creativity, industries can boost performance beyond expectations. Therefore we need the best employees who can meet this challenge!

The Power of Knowledge Engineering

Plug into The Power of Knowledge Engineering.
Visit us at www.skf.com/knowledge

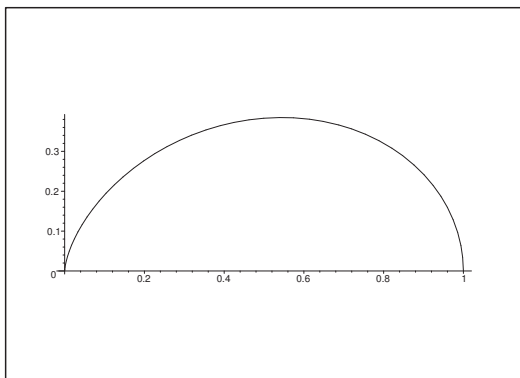

Download free books at BookBooN.com

Figure 22: The curve \mathcal{K} of **Example 2.1.4**.

hence

$$\begin{aligned} \int_{\mathcal{K}} y \, ds &= \int_0^{\pi} \varrho(\varphi) \sin \varphi \cdot a\sqrt{2} \cdot \sqrt{1 - \cos \varphi} \, d\varphi = a^2\sqrt{2} \int_0^{\pi} (1 - \cos \varphi)^{\frac{3}{2}} \sin \varphi \, d\varphi \\ &= a^2\sqrt{2} \left[\frac{2}{5}(1 - \cos \varphi)^{\frac{5}{2}} \right]_0^{\pi} = a^2\sqrt{2} \cdot \frac{2}{5} \cdot 2^{\frac{5}{2}} = \frac{16a^2}{5}. \end{aligned}$$

3) It follows from

$$\sqrt{1 + \left\{ \varrho \frac{d\varphi}{d\varrho} \right\}^2} = \sqrt{1 + \left\{ \varrho \cdot \frac{1}{\sqrt{1 - \varrho^2}} \right\}^2} = \frac{1}{\sqrt{1 - \varrho^2}},$$

that

$$\begin{aligned} \int_{\mathcal{K}} \sqrt{y} \, ds &= \int_0^1 \sqrt{\varrho \cdot \sin \varphi(\varrho)} \cdot \frac{1}{\sqrt{1 - \varrho^2}} \, d\varrho = \int_0^1 \sqrt{\varrho^2} \cdot \frac{1}{\sqrt{1 - \varrho^2}} \, d\varrho \\ &= \int_0^1 \frac{\varrho}{\sqrt{1 - \varrho^2}} \, d\varrho = \left[-\sqrt{1 - \varrho^2} \right]_0^1 = 1. \end{aligned}$$

ALTERNATIVELY, $\varrho = \sin \varphi$, $\varphi \in \left[0, \frac{\pi}{2} \right]$ and

$$\sqrt{\varrho^2 + \left(\frac{d\varrho}{d\varphi} \right)^2} = \sqrt{\sin^2 \varphi + \cos^2 \varphi} = 1,$$

thus

$$\int_{\mathcal{K}} \sqrt{y} \, ds = \int_0^{\frac{\pi}{2}} \sqrt{\sin^2 \varphi} \cdot 1 \, d\varphi = \int_0^{\frac{\pi}{2}} \sin \varphi \, d\varphi = 1.$$

4) It follows from

$$\frac{d\varrho}{d\varphi} = -2a \sin \varphi \cdot \cos \varphi,$$

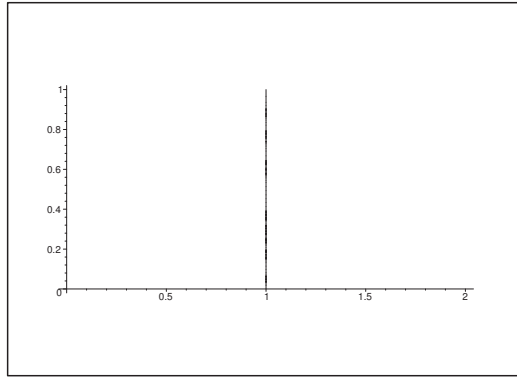

Figure 23: The curve \mathcal{K} of **Example 2.1.5**. (In fact, a segment of the line $x = a$.)

that

$$\begin{aligned}\varrho^2 + \left(\frac{d\varrho}{d\varphi}\right)^2 &= a^2 \cos^4 \varphi + 4a^2 \sin^2 \varphi \cdot \cos^2 \varphi = a^2 \cos^2 \varphi \{ \cos^2 \varphi + 4 \sin^2 \varphi \} \\ &= a^2 \cos^2 \{ 4 - 3 \cos^2 \varphi \}.\end{aligned}$$

Now, $\cos \varphi \geq 0$ for $\varphi \in \left[0, \frac{\pi}{2}\right]$, so

$$\sqrt{\varrho^2 + \left(\frac{d\varrho}{d\varphi}\right)^2} = a \cos \varphi \sqrt{4 - 3 \cos^2 \varphi},$$

and the line integral becomes

$$\begin{aligned}\int_{\mathcal{K}} \frac{y}{\sqrt{4a-3\varrho}} ds &= \int_{\mathcal{K}} \frac{\varrho \sin \varphi}{\sqrt{4a-3\varrho}} ds = \int_0^{\frac{\pi}{2}} \frac{a \cos^2 \varphi \cdot \sin \varphi}{\sqrt{4a-3a \cos^2 \varphi}} \cdot a \cos \varphi \sqrt{4-3 \cos^2 \varphi} d\varphi \\ &= a\sqrt{a} \int_0^{\frac{\pi}{2}} \cos^3 \varphi \cdot \sin \varphi d\varphi = a\sqrt{a} \left[-\frac{\cos^4 \varphi}{4} \right]_0^{\frac{\pi}{2}} = \frac{a\sqrt{a}}{4}.\end{aligned}$$

5) If $\varrho = \frac{a}{\cos \varphi}$, then

$$\frac{d\varrho}{d\varphi} = \frac{a \sin \varphi}{\cos^2 \varphi},$$

hence

$$\varrho^2 + \left(\frac{d\varrho}{d\varphi}\right)^2 = a^2 \left\{ \frac{1}{\cos^2 \varphi} + \frac{\sin^2 \varphi}{\cos^4 \varphi} \right\} = \frac{a^2}{\cos^4 \varphi},$$

where

$$\sqrt{\varrho^2 + \left(\frac{d\varrho}{d\varphi}\right)^2} = \frac{a}{\cos^2 \varphi}.$$

The line integral is obtained by insertion,

$$\int_{\mathcal{K}} \frac{1}{x^2 + y^2} ds = \int_{\mathcal{K}} \frac{1}{\varrho^2} ds = \int_0^{\pi} \frac{\cos^2 \varphi}{a^2} \cdot \frac{a}{\cos^2 \varphi} d\varphi = \frac{\pi}{4a}.$$

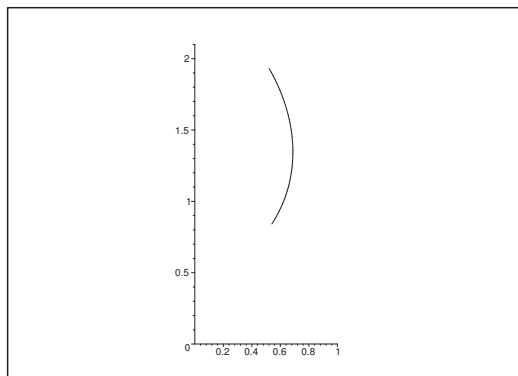
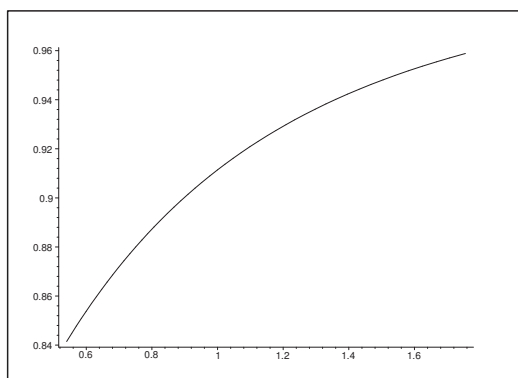
Figure 24: The curve \mathcal{K} of **Example 2.1.6**.Figure 25: The curve \mathcal{K} of **Example 2.1.7**.

6) If $\varphi = \varrho - \ln \varrho$, then

$$\frac{d\varphi}{d\varrho} = 1 - \frac{1}{\varrho} = \frac{\varrho - 1}{\varrho},$$

hence

$$\sqrt{1 + \left(\varrho \frac{d\varphi}{d\varrho}\right)^2} = \sqrt{1 + (\varrho - 1)^2}.$$

Finally, we get the line integral by insertion,

$$\begin{aligned} \int_{\mathcal{K}} \left(\sqrt{x^2 + y^2} - 1\right) ds &= \int_{\mathcal{K}} (\varrho - 1) ds = \int_1^2 \sqrt{1 + (\varrho - 1)^2} \cdot (\varrho - 1) d\varrho \\ &= \frac{1}{3} \left[\{1 + (\varrho - 1)^2\}^{\frac{3}{2}} \right]_1^2 = \frac{1}{3} (2\sqrt{2} - 1). \end{aligned}$$

7) If $\varphi = \frac{1}{\varrho}$, then $\frac{d\varphi}{d\varrho} = -\frac{1}{\varrho^2}$, så

$$\sqrt{1 + \left(\varrho \frac{d\varphi}{d\varrho}\right)^2} = \sqrt{1 + \frac{1}{\varrho^2}} = \frac{\sqrt{1 + \varrho^2}}{\varrho}.$$

We get the line integral by insertion

$$\int_{\mathcal{K}} (x^2 + y^2) ds = \int_1^2 \varrho^2 \cdot \frac{\sqrt{1 + \varrho^2}}{\varrho} d\varrho = \frac{1}{3} \left[\{1 + \varrho^2\}^{\frac{3}{2}} \right]_1^2 = \frac{1}{3} \{5\sqrt{5} - 2\sqrt{2}\}.$$

Trust and responsibility

NNE and Pharmaplan have joined forces to create NNE Pharmaplan, the world's leading engineering and consultancy company focused entirely on the pharma and biotech industries.

Inés Aréizaga Esteva (Spain), 25 years old
Education: Chemical Engineer

– You have to be proactive and open-minded as a newcomer and make it clear to your colleagues what you are able to cope. The pharmaceutical field is new to me. But busy as they are, most of my colleagues find the time to teach me, and they also trust me. Even though it was a bit hard at first, I can feel over time that I am beginning to be taken seriously and that my contribution is appreciated.

Please click the advert



NNE Pharmaplan is the world's leading engineering and consultancy company focused entirely on the pharma and biotech industries. We employ more than 1500 people worldwide and offer global reach and local knowledge along with our all-encompassing list of services.
nnepharmaplan.com

nne pharmaplan®

3 Arc lengths and parametric descriptions by the arc length

Example 3.1 Compute in each of the following cases the arc length of the plane curve \mathcal{K} given by an equation of the form $y = Y(x)$, $x \in I$.

1) The arc length $\int_{\mathcal{K}} ds$ of the curve

$$y = Y(x) = \frac{x^4 + 48}{24x}, \quad x \in [2, 4].$$

2) The arc length $\int_{\mathcal{K}} ds$ of the curve

$$y = Y(x) = a \cosh \frac{x}{a}, \quad x \in [-a, a].$$

[Cf. **Example 3.4.1** and **Example 4.1.8**.]

3) The arc length $\int_{\mathcal{K}} ds$ of the curve

$$y = Y(x) = \ln \frac{e^x - 1}{e^x + 1}, \quad x \in [2, 4].$$

4) The arc length $\int_{\mathcal{K}} ds$ of the curve

$$y = Y(x) = x^{\frac{3}{2}}, \quad x \in [0, 1].$$

5) The arc length $\int_{\mathcal{K}} ds$ of the curve

$$y = Y(x) = x^{\frac{2}{3}}, \quad x \in [0, 1].$$

A Arc lengths of plane curves.

D Sketch the plane curve. Calculate the weight function $\sqrt{1 + Y'(x)^2}$ and reduce the line integral of integrand 1 to an ordinary integral.

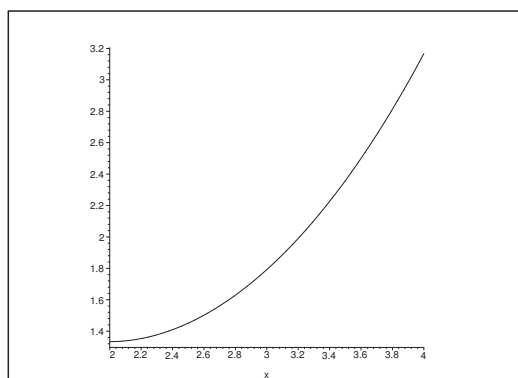

Figure 26: The curve \mathcal{K} of **Example 3.1.1**.

I 1) It follows from

$$Y(x) = \frac{x^3}{24} + \frac{2}{x}, \quad \text{thus} \quad Y'(x) = \frac{x^2}{8} - \frac{2}{x^2} = \frac{x^4 - 16}{8x^2},$$

that

$$\sqrt{1 + Y'(x)^2} = \frac{1}{8x^2} \sqrt{64x^4 + (x^4 - 16)^2} = \frac{1}{8x^2} (x^4 + 16) = \frac{x^2}{8} + \frac{2}{x^2}.$$

We get the arc length by insertion,

$$\begin{aligned} \int_{\mathcal{K}} ds &= \int_2^4 \sqrt{1 + Y'(x)^2} dx = \int_2^4 \left\{ \frac{x^2}{8} + \frac{2}{x^2} \right\} dx = \left[\frac{x^3}{24} - \frac{2}{x} \right]_2^4 \\ &= \frac{64 - 8}{24} - \frac{2}{4} + \frac{2}{2} = \frac{56}{24} - \frac{1}{2} + 1 = \frac{7}{3} + \frac{1}{2} = \frac{17}{6}. \end{aligned}$$

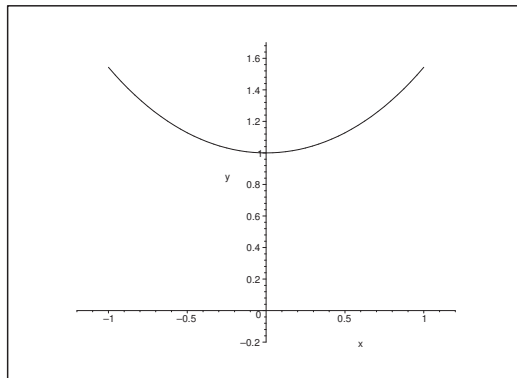

Figure 27: The curve \mathcal{K} of **Example 3.1.2** for $a = 1$.

2) From $Y'(x) = \sinh \frac{x}{a}$ follows that

$$\sqrt{1 + Y'(x)^2} = \sqrt{1 + \sinh^2 \left(\frac{x}{a} \right)} = \cosh \frac{x}{a}.$$

The arc length is

$$\int_{\mathcal{K}} ds = \int_{-a}^a \cosh \frac{x}{a} dx = a \left[\sinh \frac{x}{a} \right]_{-a}^a = 2a \sinh 1 = \frac{a}{e} (e^2 - 1).$$

3) It follows from

$$Y'(x) = \frac{e^x}{e^x - 1} - \frac{e^x}{e^x + 1} = \frac{2e^x}{e^{2x} - 1},$$

that

$$\sqrt{1 + Y'(x)^2} = \frac{1}{e^{2x} - 1} \sqrt{(e^{2x} - 1)^2 + 4e^{2x}} = \frac{e^{2x} + 1}{e^{2x} - 1} = \frac{\cosh x}{\sinh x},$$

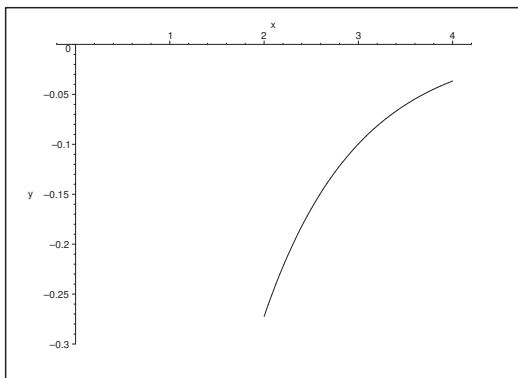

Figure 28: The curve \mathcal{K} of **Example 3.1.3**.

so the arc length becomes

$$\begin{aligned} \int_{\mathcal{K}} ds &= \int_2^4 \frac{\cosh x}{\sinh x} dx = [\ln \sinh x]_2^4 = \ln \left(\frac{\sinh 4}{\sinh 2} \right) = \ln \left(\frac{2 \sinh 2 \cosh 2}{\sinh 2} \right) \\ &= \ln(2 \cosh 2) = \ln(e^2 + e^{-2}) = \ln(e^4 + 1) - 2. \end{aligned}$$

4) Here, $Y'(x) = \frac{3}{2} \sqrt{x}$, so

$$\sqrt{1 + Y'(x)^2} = \sqrt{1 + \frac{9}{4}x}.$$

The arc length is

$$\int_{\mathcal{K}} ds = \int_0^1 \sqrt{1 + \frac{9}{4}x} dx = \frac{4}{9} \cdot \frac{2}{3} \left[\left(1 + \frac{9}{4}x\right)^{\frac{3}{2}} \right]_0^1 = \frac{8}{27} \left\{ \left(\frac{13}{4}\right)^{\frac{3}{2}} - 1 \right\} = \frac{1}{27} \{13\sqrt{13} - 8\}.$$

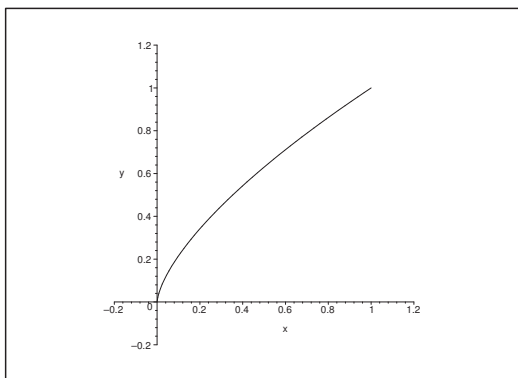

Figure 29: The curve \mathcal{K} of **Example 3.1.5**.

- 5) Since the arc length of $y = x^{\frac{2}{3}}$, $x \in [0, 1]$, is equal to the arc length of $x = y^{\frac{3}{2}}$, it follows from **Example 3.1.4** that

$$\int_{\mathcal{K}} ds = \frac{1}{27} \{13\sqrt{13} - 9\}.$$

ALTERNATIVELY, $Y'(x) = \frac{2}{3} x^{-\frac{1}{3}}$, thus

$$\begin{aligned} \int_{\mathcal{K}} ds &= \int_0^1 \sqrt{1 + \frac{4}{9} x^{-\frac{2}{3}}} dx = \int_0^1 x^{-\frac{1}{3}} \sqrt{x^{\frac{2}{3}} + \frac{4}{9}} dx = \frac{3}{2} \int_0^1 \sqrt{t + \frac{4}{9}} dt \\ &= \left[\left(t + \frac{4}{9} \right)^{\frac{3}{2}} \right]_0^1 = \left(\frac{13}{9} \right)^{\frac{3}{2}} - \left(\frac{4}{9} \right)^{\frac{3}{2}} = \frac{13\sqrt{13}}{27} - \frac{8}{27} = \frac{1}{27} \{13\sqrt{13} - 8\}. \end{aligned}$$

Please click the advert

THE MILKWAY
LAUNCHING GRADUATE CAREERS

MILKROUND SYSTEM
Become a business star with internships, placements, graduate jobs & schemes from leading companies.
www.milkround.com

PLANET CAREER ADVICE
Inhabited by insights into business careers and orbited by application advice.

FIRST CONTACT
Get matched to top business employers via intelligent emails landing in your inbox.

Milkround.com: rated the #1 graduate recruitment website in the UK Graduate Careers Survey 2009 of 16,000 university finalists.

Milkround.com

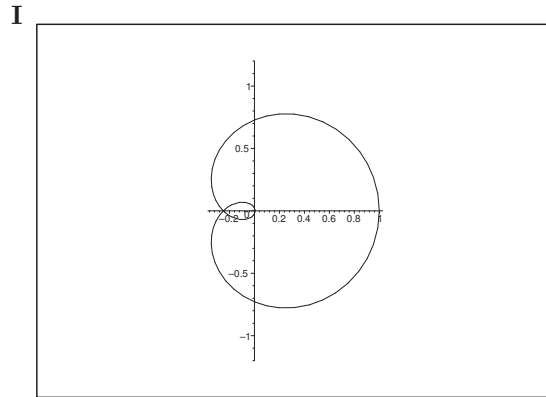
Figure 30: The curve \mathcal{K} of **Example 3.2.1**.

Example 3.2 Compute in each of the following cases the arc length of the given plane curve \mathcal{K} by an equation in polar coordinates.

1) The arc length $\int_{\mathcal{K}} ds$ of the curve given by

$$\rho = a \cos^4 \frac{\varphi}{4}, \quad \varphi \in [0, 4\pi].$$

2) The arc length $\int_{\mathcal{K}} ds$ of the curve given by

$$\rho = a(1 + \cos \varphi), \quad \varphi \in [0, 2\pi].$$

3) The arc length $\int_{\mathcal{K}} ds$ of the curve given by

$$\varphi = \ln \rho, \quad \rho \in [1, e].$$

4) The arc length $\int_{\mathcal{K}} ds$ of the curve given by

$$\rho = a \sin^3 \frac{\varphi}{3}, \quad \varphi \in [0, 3\pi].$$

A Arc lengths in polar coordinates.

D First calculate the weight function $\sqrt{\rho^2 + \left(\frac{d\rho}{d\varphi}\right)^2}$ (possibly $\sqrt{1 + \left(\rho \frac{d\varphi}{d\rho}\right)^2}$), and then the line integral.

1) Since

$$\frac{d\rho}{d\varphi} = -a \cdot \cos^3 \frac{\varphi}{4} \cdot \sin \frac{\varphi}{4},$$

the weight is given by

$$\rho^2 + \left(\frac{d\rho}{d\varphi}\right)^2 = a^2 \cos^8 \frac{\varphi}{4} + a^2 \cos^6 \frac{\varphi}{4} \cdot \sin^2 \frac{\varphi}{4} = a^2 \cos^6 \frac{\varphi}{4},$$

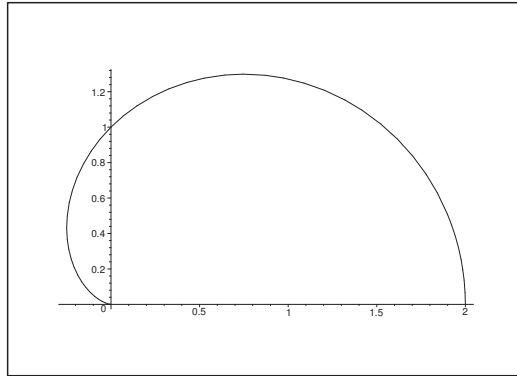
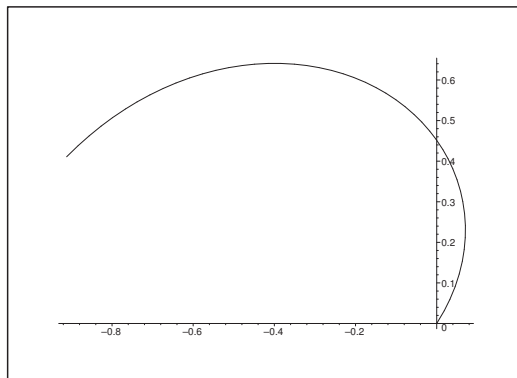
Figure 31: The curve \mathcal{K} of **Example 3.2.2**.Figure 32: The curve \mathcal{K} of **Example 3.2.3**. (Part of the curve of **Example 2.1.2**).

hence

$$\begin{aligned} \int_{\mathcal{K}} ds &= \int_0^{4\pi} \sqrt{\varrho^2 + \left(\frac{d\varrho}{d\varphi}\right)^2} d\varphi = \int_0^{4\pi} a \left| \cos^3 \frac{\varphi}{4} \right| d\varphi = 4a \int_0^{\pi} |\cos^3 t| dt \\ &= 8a \int_0^{\frac{\pi}{2}} \cos^3 t dt = 8a \int_0^{\frac{\pi}{2}} (1 - \sin^2 t) \cos t dt = 8a \left[\sin t - \frac{1}{3} \sin^3 t \right]_0^{\frac{\pi}{2}} = \frac{16a}{3}. \end{aligned}$$

2) In this case,

$$\sqrt{\varrho^2 + \left(\frac{d\varrho}{d\varphi}\right)^2} = a\sqrt{(1 + \cos \varphi)^2 + \sin^2 \varphi} = a\sqrt{2(1 + \cos \varphi)} = a\sqrt{4 \cos^2 \frac{\varphi}{2}} = 2a \left| \cos \frac{\varphi}{2} \right|,$$

so

$$\int_{\mathcal{K}} ds = \int_0^{2\pi} 2a \left| \cos \frac{\varphi}{2} \right| d\varphi = 4a \int_0^{\pi} |\cos t| dt = 8a \int_0^{\frac{\pi}{2}} \cos t dt = 8a.$$

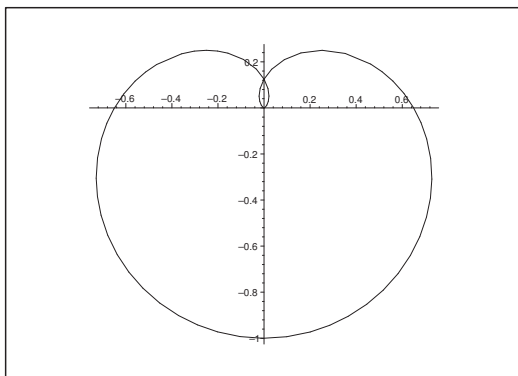
Figure 33: The curve \mathcal{K} of **Example 3.2.4**.

3) From

$$\sqrt{1 + \left\{ \varrho \frac{d\varphi}{d\varrho} \right\}^2} = \sqrt{1 + \left\{ \varrho \cdot \frac{1}{\varrho} \right\}^2} = \sqrt{2},$$

follows that

$$\int_{\mathcal{K}} ds = \int_1^e \sqrt{2} d\varrho = \sqrt{2}(e-1).$$

ALTERNATIVELY, $\varrho = e^\varphi$, $\varphi \in [0, 1]$, so (cf. **Example 2.1.1**)

$$\sqrt{\varrho^2 + \left(\frac{d\varrho}{d\varphi} \right)^2} = \sqrt{2} e^\varphi,$$

hence

$$\int_{\mathcal{K}} ds = \int_0^1 \sqrt{2} e^\varphi d\varphi = \sqrt{2}(e-1).$$

4) Here $\frac{d\varrho}{d\varphi} = a \cdot \sin^2 \frac{\varphi}{3} \cdot \cos \frac{\varphi}{3}$, so

$$\sqrt{\varrho^2 + \left(\frac{d\varrho}{d\varphi} \right)^2} = a \sqrt{\sin^6 \frac{\varphi}{3} + \sin^4 \frac{\varphi}{3} \cdot \cos^2 \frac{\varphi}{3}} = a \cdot \sin^2 \frac{\varphi}{3},$$

thus

$$\int_{\mathcal{K}} ds = \int_0^{3\pi} a \sin^2 \frac{\varphi}{3} d\varphi = 3a \int_0^\pi \sin^2 t dt = \frac{3a}{2} \int_0^\pi (1 - \cos 2t) dt = \frac{3a\pi}{2}.$$

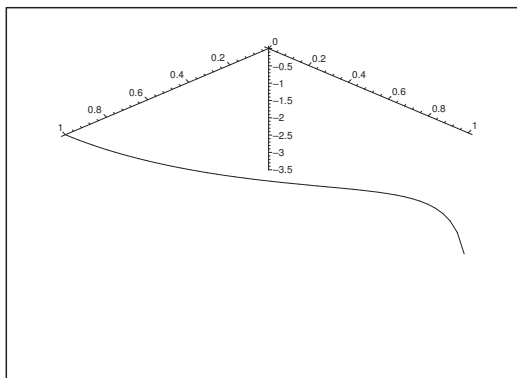

Figure 34: The space curve of **Example 3.3.1**.

Example 3.3 Below are given some space curves by their parametric descriptions $\mathbf{x} = \mathbf{r}(t)$, $t \in I$. Express for each of the curves their parametric description with respect to arc length from the point of the parametric value t_0 .

1) The curve $\mathbf{r}(t) = (\cos t, \sin t, \ln \cos t)$, from $t_0 = 0$ in the interval $I = \left[0, \frac{\pi}{2}\right[$.

2) The curve $\mathbf{r}(t) = \frac{1}{\sqrt{3}} (e^t \cos t, e^t \sin t, e^t)$ from $t_0 = 0$ in the interval $I = \mathbb{R}$.

[Cf. **Example 1.1.7**.]

3) The curve $\mathbf{r}(t) = (\ln \cos t, \ln \sin t, \sqrt{2}t)$ from $t_0 = \frac{\pi}{4}$ in the interval $I = \left]0, \frac{\pi}{2}\right[$.

4) The curve $\mathbf{r}(t) = (7t + \cos t, 7t - \cos t, \sqrt{2} \sin t)$ from $t_0 = \frac{\pi}{2}$ in the interval $I = \mathbb{R}$.

5) The curve $\mathbf{r}(t) = (\cos(2t), \sin(2t), 2 \cosh t)$ from $t_0 = 0$ in the interval $I = \mathbb{R}$.

6) The curve $\mathbf{r}(t) = (\cos t, \sin t, \ln \cos t)$ from $t_0 = 0$ in the interval $I = \left]-\frac{\pi}{2}, \frac{\pi}{2}\right[$.

[Cf. **Example 1.1.5**.]

A Parametric description by the arc length.

D Find $s'(t) = \|\mathbf{r}'(t)\|$ and then $s = s(t)$ and $t = \tau(s)$, where we integrate from t_0 . Finally, insert in $\mathbf{x} = \mathbf{r}(t) = \mathbf{r}(\tau(s))$.

I 1) From

$$\mathbf{r}'(t) = \left(-\sin t, \cos t, -\frac{\sin t}{\cos t}\right), \quad t \in \left[0, \frac{\pi}{2}\right[,$$

follows that

$$s'(t) = \|\mathbf{r}'(t)\| = \sqrt{\sin^2 t + \cos^2 t + \frac{\sin^2 t}{\cos^2 t}} = \frac{1}{\cos t},$$

hence

$$\begin{aligned} s(t) &= \int_0^t \frac{1}{\cos u} du = \int_0^t \frac{\cos u}{1 - \sin^2 u} du = \int_0^t \frac{1}{2} \left(\frac{1}{1 + \sin u} + \frac{1}{1 - \sin u} \right) \cos u du \\ &= \frac{1}{2} \left[\ln \left(\frac{1 + \sin u}{1 - \sin u} \right) \right]_0^t = \frac{1}{2} \ln \left(\frac{1 + \sin t}{1 - \sin t} \right). \end{aligned}$$

Please click the advert



CHALLENGE YOURSELF

WWW.STUDYINSWEDEN.SE

Today's job market values ambitious, innovative, perceptive team players. Swedish universities foster these qualities through a forward-thinking culture where you're close to the latest ideas and global trends.

Whatever your career goals may be, studying in Sweden will give you valuable skills and a competitive advantage for your future. www.studyinsweden.se

Si.
Swedish Institute

Download free books at BookBooN.com

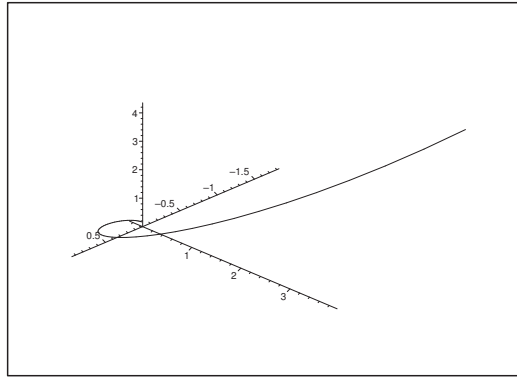
Figure 35: The space curve of **Example 3.3.2**.

Then

$$\frac{1 + \sin t}{1 - \sin t} = e^{2s}, \quad \text{dvs.} \quad \sin t = \frac{e^{2s} - 1}{e^{2s} + 1} = \tanh s, \quad s \geq 0.$$

Notice that it follows from $t \in \left[0, \frac{\pi}{2}\right[$ that

$$\cos t = \frac{2e^s}{e^{2s} + 1} = \frac{1}{\cosh s}.$$

Thus

$$t = \text{Arcsin}\left(\frac{e^{2s} - 1}{e^{2s} + 1}\right) = \text{Arcsin}(\tanh s), \quad s \geq 0,$$

and the parametric description by the arc length is

$$\begin{aligned} \mathbf{r}(s) &= (\cos t, \sin t, \ln \cos t) = \left(\frac{2e^s}{e^{2s} + 1}, \frac{e^{2s} - 1}{e^{2s} + 1}, \ln\left(\frac{2e^s}{e^{2s} + 1}\right)\right) \\ &= \left(\frac{1}{\cosh s}, \tanh s, -\ln \cosh s\right), \quad s \geq 0. \end{aligned}$$

2) Here

$$\mathbf{r}'(t) = \frac{1}{\sqrt{3}} e^t (\cos t - \sin t, \cos t + \sin t, 1),$$

so

$$s'(t) = \|\mathbf{r}'(t)\| = \frac{1}{\sqrt{3}} e^t \sqrt{(\cos t - \sin t)^2 + (\cos t + \sin t)^2 + 1} = e^t,$$

hence

$$s(t) = \int_0^t e^u du = e^t - 1, \quad \text{and} \quad t = \ln(s + 1), \quad s > -1.$$

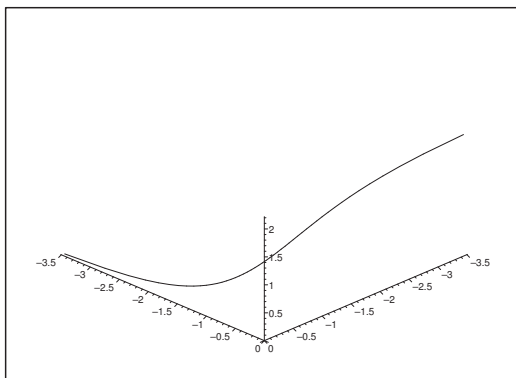

Figure 36: The space curve of **Example 3.3.3**.

Finally, we get the parametric description by the arc length,

$$\begin{aligned} \mathbf{r}(s) &= \frac{1}{\sqrt{3}} ((s + 1) \cos(\ln(s + 1)), (s + 1) \sin(\ln(s + 1)), s + 1) \\ &= \frac{s + 1}{\sqrt{3}} (\cos(\ln(s + 1)), \sin(\ln(s + 1)), 1), \quad s > -1. \end{aligned}$$

3) From

$$\mathbf{r}'(t) = \left(-\frac{\sin t}{\cos t}, \frac{\cos t}{\sin t}, \sqrt{2} \right), \quad t \in \left] 0, \frac{\pi}{2} \right[,$$

follows that

$$s'(t) = \|\mathbf{r}'(t)\| = \sqrt{\frac{\sin^2 t}{\cos^2 t} + 2 + \frac{\cos^2 t}{\sin^2 t}} = \frac{\sin t}{\cos t} + \frac{\cos t}{\sin t} = \frac{1}{\cos t \sin t},$$

as $t \in \left] 0, \frac{\pi}{2} \right[$. Then

$$s(t) = \int_{\frac{\pi}{4}}^t \frac{1}{\cos u \sin u} du = \int_{\frac{\pi}{4}}^t \left(\frac{\sin u}{\cos u} + \frac{\cos u}{\sin u} \right) du = \ln \frac{\sin t}{\cos t} = \ln \tan t,$$

and thus $s \in \mathbb{R}$ and $\tan t = e^s$, and

$$\cos t = \frac{+1}{\sqrt{1 + \tan^2 t}} = \frac{1}{\sqrt{1 + e^{2s}}}, \quad \text{and} \quad \sin t = \frac{e^s}{\sqrt{1 + e^{2s}}}.$$

The parametric description by the arc length is

$$\mathbf{r}(s) = \left(-\frac{1}{2} \ln(1 + e^{2s}), s - \frac{1}{2} \ln(1 + e^{2s}), \sqrt{2} \operatorname{Arctan}(e^s) \right), \quad s \in \mathbb{R}.$$

4) Here,

$$\mathbf{r}'(t) = (7 - \sin t, 7 + \sin t, \sqrt{2} \cos t),$$

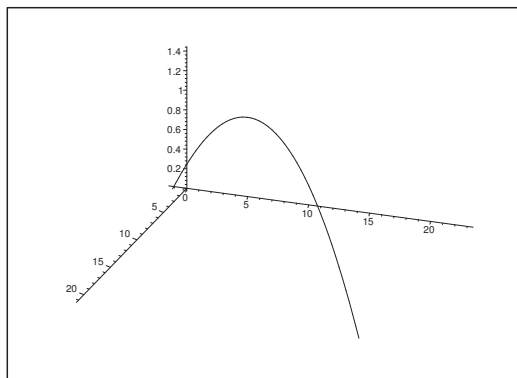
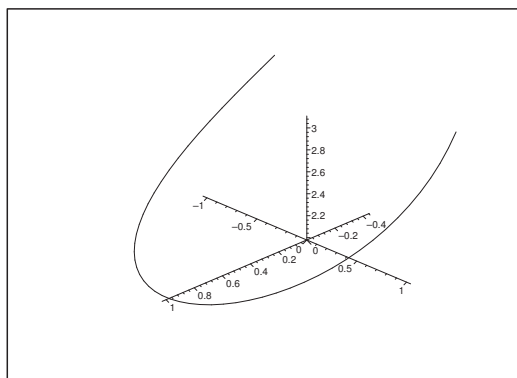
Figure 37: The space curve of **Example 3.3.4**.Figure 38: The space curve of **Example 3.3.5**.

so

$$\begin{aligned} s'(t) &= \|\mathbf{r}'(t)\| = \sqrt{(7 - \sin t)^2 + (7 + \sin t)^2 + 2 \cos^2 t} \\ &= \sqrt{2 \cdot 49 + 2 \sin^2 t + 2 \cos^2 t} = \sqrt{98 + 2} = 10, \end{aligned}$$

and thus

$$s(t) = \int_{\frac{\pi}{2}}^t 10 \, du = 10 \left(t - \frac{\pi}{2} \right), \quad \text{so} \quad t = \frac{s}{10} + \frac{\pi}{2}, \quad s \in \mathbb{R},$$

and the parametric description with the arc length as parameter from the point $\left(\frac{7\pi}{2}, \frac{7\pi}{2}, \sqrt{2} \right)$ is

$$\mathbf{r}(s) = \left(\frac{7s + 35\pi}{10} - \sin\left(\frac{s}{10}\right), \frac{7s + 35\pi}{10} + \sin\left(\frac{s}{10}\right), \sqrt{2} \cos\left(\frac{s}{10}\right) \right),$$

for $s \in \mathbb{R}$.

5) It follows from

$$\mathbf{r}'(t) = (-2 \sin 2t, 2 \cos 2t, 2 \sinh t),$$

Please click the advert



DIVERSE - INNOVATIVE - INTERNATIONAL

Are you considering a European business degree?

Copenhagen Business School is one of the largest business schools in Northern Europe with more than 15,000 students from Europe, North America, Australia and Asia.

Are you curious to know how a modern European business school competes with a diverse, innovative and international study environment?

Please visit Copenhagen Business School at www.cbs.dk

Copenhagen Business School
HANDELSHØJSKOLEN

Diversity creating knowledge

P I M
Partnership in International Management

Accredited by
Association of MBAs

EFMD
EQUIS
ACCREDITED

MEMBER OF
CEMS

Download free books at BookBooN.com

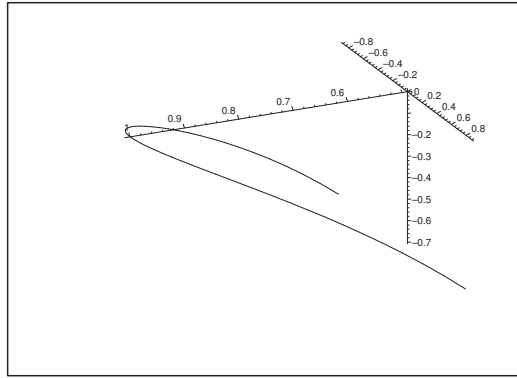

Figure 39: The space curve of **Example 3.3.6**; cf. **Example 3.3.1**.

that

$$s'(t) = \|\mathbf{r}'(t)\| = 2\sqrt{\sin^2(2t) + \cos^2(2t) + \sinh^2 t} = 2 \cosh t,$$

hence

$$s(t) = \int_0^t 2 \cosh u \, du = 2 \sinh t,$$

so $s \in \mathbb{R}$ and

$$t = \operatorname{Arsinh}\left(\frac{s}{2}\right) = \ln\left(\frac{1}{2}\left(s + \sqrt{s^2 + 4}\right)\right), \quad s \in \mathbb{R}.$$

The parametric description with the arc length as parameter is

$$\begin{aligned} \mathbf{r}(s) &= \left(\cos\left(2 \operatorname{Arsinh}\left(\frac{s}{2}\right)\right), \sin\left(2 \operatorname{Arsinh}\left(\frac{s}{2}\right)\right), 2\sqrt{1 + \frac{s^2}{4}} \right) \\ &= \left(\cos\left(2 \operatorname{Arsinh}\left(\frac{s}{2}\right)\right), \sin\left(2 \operatorname{Arsinh}\left(\frac{s}{2}\right)\right), \sqrt{4 + s^2} \right), \end{aligned}$$

for $s \in \mathbb{R}$.

- 6) This is an extension of the curve of **Example 3.3.1**, with the same parametric description evaluated from the same point $t_0 = 0$. We can therefore reuse this example, since the only change is that $s \in \mathbb{R}$,

$$\mathbf{r}(s) = \left(\frac{1}{\cosh s}, \tanh s, -\ln \cosh s \right), \quad \text{for } s \in \mathbb{R}.$$

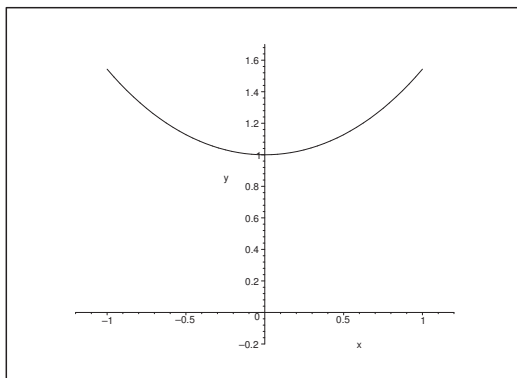

Figure 40: The chain curve for $a = 1$, cf. **Example 3.4.1**.

Example 3.4 Find for every one of the given plane curves below an equation of the form

(1) $\psi = \Psi(s)$,

where the signed arc length s is computed from a fixed point P_0 on the curve, while ψ is the angle between the oriented tangents at P_0 and at the point P on the curve given by s .

1) The chain curve given by $y = a \cosh \frac{x}{a}$, from P_0 given by $x = 0$.

[Cf. **Example 1.2.2**.]

2) The asteroïd given by

$$\mathbf{r}(t) = a(-\cos^3 t, \sin^3 t), \quad t \in \left[0, \frac{\pi}{2}\right],$$

from P_0 given by $t = 0$.

3) The winding of a circle given by

$$\mathbf{r}(t) = a(\cos t + t \sin t, \sin t - t \cos t), \quad t \in \mathbb{R}_+,$$

from P_0 given by $t = 0$.

4) The cycloid given by

$$\mathbf{r}(t) = a(t - \sin t, 1 - \cos t), \quad t \in [0, 2\pi],$$

from P_0 given by $t = \pi$.

It can be proved that (1) determines the curve uniquely with exception of its placement in the plane. Therefore, (1) is also called the natural equation of the curve.

A Natural equation.

D Find the arc length s , and then ψ by a geometrical analysis.

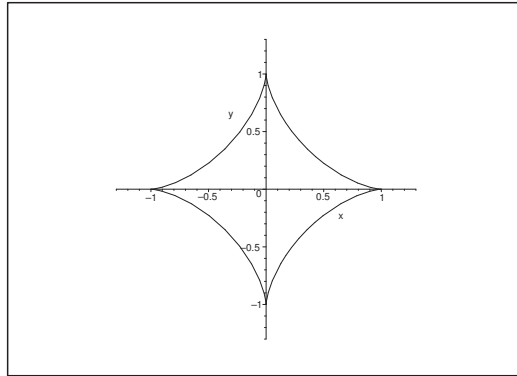
Figure 41: The asteroïd of **Example 3.4.2**.

- 1) The point P_0 has the coordinates $(0, a)$. A parametric description of the chain curve is e.g.

$$\mathbf{r}(t) = \left(t, a \cosh \frac{t}{a} \right),$$

hence

$$\mathbf{r}'(t) = \left(1, \sinh \frac{t}{a} \right), \quad \text{where } \mathbf{r}'(0) = (1, 0),$$

and thus $\psi = \text{Arctan} \left(\sinh \frac{t}{a} \right)$.

From

$$s'(t) = \|\mathbf{r}'(t)\| = \sqrt{1 + \sinh^2 \frac{t}{a}} = \cosh \frac{t}{a},$$

follows that

$$s(t) = \int_0^t \cosh \frac{u}{a} dy = a \left[\sinh \frac{u}{a} \right]_0^t = a \sinh \left(\frac{t}{a} \right).$$

The natural equation is

$$\psi = \Psi(s) = \text{Arctan} \left(\frac{s}{a} \right).$$

- 2) The point P_0 has the coordinates $(-a, 0)$, and

$$\mathbf{r}'(t) = a (3 \cos^2 t \cdot \sin t, 3 \sin^2 t \cdot \cos t) = 3a \cos t \cdot \sin t (\cos t, \sin t).$$

For $t \rightarrow 0+$ we get $\mathbf{r}'(0) = \mathbf{0}$, and by considering a figure we may conclude that we have a horizontal half tangent. Then it follows that $\psi = t$.

It follows from

$$s'(t) = \|\mathbf{r}'(t)\| = 3a \cos t \cdot \sin t,$$

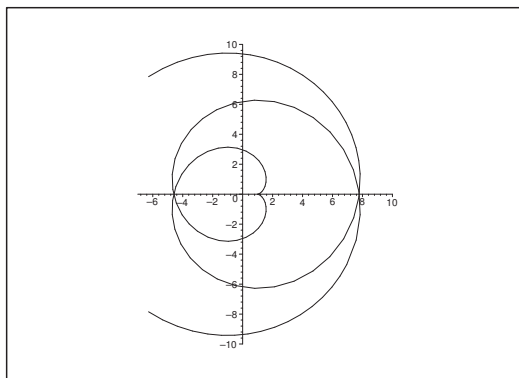

Figure 42: The winding of the circle of **Example 3.4.3**.

that

$$s(t) = \int_0^t 3a \cos u \cdot \sin u \, du = \frac{3a}{2} \int_0^t \sin 2u \, du = \frac{3a}{4} \{1 - \cos 2t\},$$

hence

$$\cos 2t = 1 - \frac{4s}{3a},$$

and

$$\psi = \Psi(s) = t = \frac{1}{2} \operatorname{Arccos} \left(1 - \frac{4s}{3a} \right).$$

3) The point P_0 has the coordinates $(a, 0)$, and

$$\mathbf{r}'(t) = a(-\sin t + \sin t + t \cos t, \cos t - \cos t + t \sin t) = at(\cos t, \sin t).$$

It follows that $\psi = t$.

As $t > 0$ we have

$$s'(t) = \|\mathbf{r}'(t)\| = at,$$

thus

$$s(t) = a \int_0^t u \, du = \frac{a}{2} t^2, \quad s \hat{=} at = \sqrt{\frac{2s}{a}},$$

and hence

$$\psi = \Psi(s) = \sqrt{\frac{2s}{a}}.$$

4) The point P_0 is described by $\mathbf{r}(\pi) = a(\pi, 0)$. The curve has a vertical half tangent at P_0 . From

$$\mathbf{r}'(t) = a(1 - \cos t, \sin t) = a \left(2 \sin^2 \frac{t}{2}, 2 \sin \frac{t}{2} \cos \frac{t}{2} \right) = 2a \sin \frac{t}{2} \left(\sin \frac{t}{2}, \cos \frac{t}{2} \right),$$

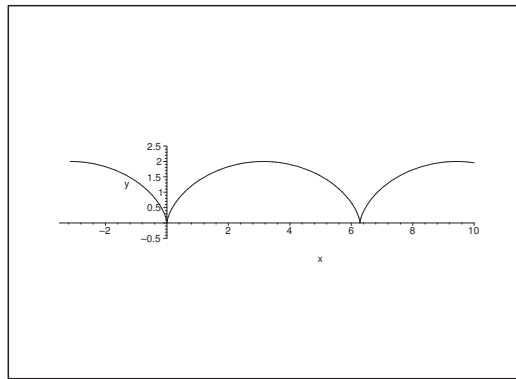

Figure 43: The cycloid of Example 3.4.4.

follows that

$$s'(t) = \|\mathbf{r}'(t)\| = 2a \sin \frac{t}{2},$$

Please click the advert



Sharp Minds - Bright Ideas!

Employees at FOSS Analytical A/S are living proof of the company value - First - using new inventions to make dedicated solutions for our customers. With sharp minds and cross functional teamwork, we constantly strive to develop new unique products - Would you like to join our team?

FOSS works diligently with innovation and development as basis for its growth. It is reflected in the fact that more than 200 of the 1200 employees in FOSS work with Research & Development in Scandinavia and USA. Engineers at FOSS work in production, development and marketing, within a wide range of different fields, i.e. Chemistry, Electronics, Mechanics, Software, Optics, Microbiology, Chemometrics.

We offer
A challenging job in an international and innovative company that is leading in its field. You will get the opportunity to work with the most advanced technology together with highly skilled colleagues.

Read more about FOSS at www.foss.dk - or go directly to our student site www.foss.dk/sharpminds where you can learn more about your possibilities of working together with us on projects, your thesis etc.

The Family owned FOSS group is the world leader as supplier of dedicated, high-tech analytical solutions which measure and control the quality and production of agricultural, food, pharmaceutical and chemical products. Main activities are initiated from Denmark, Sweden and USA with headquarters domiciled in Hillerød, DK. The products are marketed globally by 23 sales companies and an extensive net of distributors. In line with the corevalue to be 'First', the company intends to expand its market position.

Dedicated Analytical Solutions

FOSS
 Slangerupgade 69
 3400 Hillerød
 Tel. +45 70103370
www.foss.dk



so

$$s(t) = \int_{\pi}^t 2a \sin \frac{u}{2} du = 4a \left[-\cos \frac{u}{2} \right]_{\pi}^t = 4a \left\{ -\cos \frac{t}{2} \right\},$$

and hence

$$\cos \frac{t}{2} = -\frac{s}{4a}, \quad \text{dvs.} \quad t = 2 \operatorname{Arccos} \left(-\frac{s}{4a} \right).$$

Since ψ must have the form $at + b$, it is easy to derive that

$$\psi = \pi - t = \pi - 2 \operatorname{Arccos} \left(-\frac{s}{4a} \right).$$

Example 3.5 A plane curve \mathcal{K} is given by the parametric description

$$\mathbf{r}(t) = \left(a \int_0^t \sin(u^2) du, a \int_0^t \cos(u^2) du \right), \quad t \in \mathbb{R}.$$

The signed arc length from the point $(0,0)$ is called s .

1. Find s , and find the parametric description of the curve given by the arc length.

It is proved in Differential Geometry that any plane curve has a curvature

$$\kappa(t) = \frac{\{\mathbf{e}_z \times \mathbf{r}'(t)\} \cdot \mathbf{r}''(t)}{\|\mathbf{r}'(t)\|^3},$$

where we let the plane of the curve be the (X, Y) -plane in the space.

2. Prove that κ is proportional to s for \mathcal{K} .

The curve under consideration has many names: the clothoid, Euler's spiral, Cornu's spiral.

REMARK. "Clothoid" means in koiné, i.e. Ancient Greek: $\kappa\lambda\omega\theta\omega = \text{I spin}$. \diamond

A Parametric description with respect to arc length, curvature.

D Find ds and then compute.

I 1) As $s'(t) = \|\mathbf{r}'(t)\|$ and $\mathbf{r}'(t) = a(\sin(t^2), \cos(t^2))$, fås

$$s'(t) = a\sqrt{\sin^2(t^2) + \cos^2(t^2)} = a,$$

we get

$$s(t) = at \quad \text{and} \quad t(s) = \frac{1}{a}s.$$

The parametric description with the arc length is

$$\mathbf{x} = \mathbf{r}(t) = a \left(\int_0^t \sin(u^2) du, \int_0^t \cos(u^2) du \right) = a \left(\int_0^{\frac{s}{a}} \sin(u^2) du, \int_0^{\frac{s}{a}} \cos(u^2) du \right).$$

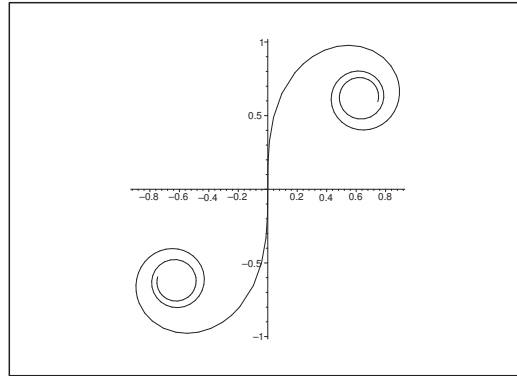
Figure 44: The clothoid for $a = 1$ and $s \in [-4, 4]$.

2) From

$$\mathbf{r}'(t) = a (\sin(t^2), \cos(t^2)) \sim a (\sin(t^2), \cos(t^2), 0),$$

and

$$\mathbf{r}''(t) = 2ta (\cos(t^2), -\sin(t^2)) \sim 2ta (\cos(t^2), -\sin(t^2), 0),$$

follows that

$$\begin{aligned} \{\mathbf{e}_z \times \mathbf{r}'(t)\} \cdot \mathbf{r}''(t) &= \begin{vmatrix} 2ta \cos(t^2) & -2ta \sin(t^2) & 0 \\ 0 & 0 & 1 \\ a \sin(t^2) & a \cos(t^2) & 0 \end{vmatrix} = - \begin{vmatrix} 2ta \cos(t^2) & -2ta \sin(t^2) \\ a \sin(t^2) & a \cos(t^2) \end{vmatrix} \\ &= -2ta^2. \end{aligned}$$

As $\|\mathbf{r}'(t)\| = a$, we finally get

$$\kappa = \frac{\{\mathbf{e}_z \times \mathbf{r}'(t)\} \cdot \mathbf{r}''(t)}{\|\mathbf{r}'(t)\|^3} = -\frac{2ta^2}{a^3} = -2 \frac{t}{a} = -\frac{2s}{a^2}.$$

Example 3.6 A space curve \mathcal{K} is given by the parametric description

$$\mathbf{r}(t) = \left(\frac{1}{2}t^2 - \ln t, 2 \sin t, 2 \cos t \right), \quad t \in [1, 2].$$

Prove that $\|\mathbf{r}'(t)\| = t + \frac{1}{t}$, and find the length of \mathcal{K} .

A Arc length.

D Compute $\|\mathbf{r}'(t)\|$ og $\ell = \int_0^1 \|\mathbf{r}'(t)\| dt$.

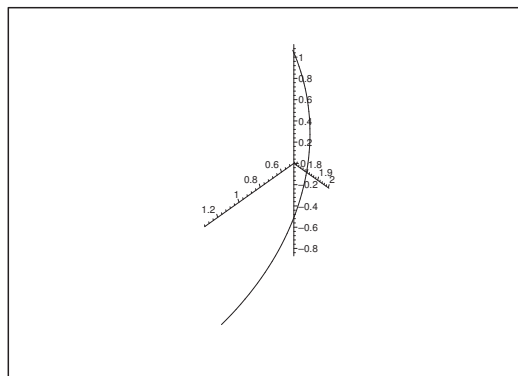
Figure 45: The curve \mathcal{K} .

I It follows from

$$\mathbf{r}'(t) = \left(t - \frac{1}{t}, 2 \cos t, -2 \sin t \right), \quad t \in [1, 2],$$

that

$$\|\mathbf{r}'(t)\|^2 = \left(t - \frac{1}{t} \right)^2 + 4 \cos^2 t + 4 \sin^2 t = t^2 - 2 + \frac{1}{t^2} = \left(t + \frac{1}{t} \right)^2,$$

thus

$$\|\mathbf{r}'(t)\| = \left| t + \frac{1}{t} \right| = t + \frac{1}{t},$$

and accordingly,

$$\ell = \int_1^2 \|\mathbf{r}'(t)\| dt = \int_1^2 \left(1 + \frac{1}{t} \right) dt = \left[\frac{t^2}{2} + \ln t \right]_1^2 = \frac{3}{2} + \ln 2.$$

Example 3.7 A space curve \mathcal{K} is given by the parametric description

$$\mathbf{r}(t) = \left(e^{3t}, e^{-3t}, \sqrt{18}t \right), \quad t \in [-1, 1].$$

Prove that $\|\mathbf{r}'(t)\| = 3(e^{3t} + e^{-3t})$, and find the arc length of \mathcal{K} .

A Arc length.

D Find $\mathbf{r}'(t)$.

I We get by differentiation

$$\mathbf{r}'(t) = \left(3e^{3t}, -3e^{-3t}, 3\sqrt{2} \right) = 3 \left(e^{3t}, -e^{-3t}, \sqrt{2} \right),$$

thus

$$\|\mathbf{r}'(t)\| = 3\sqrt{(e^{3t})^2 + (-e^{-3t})^2 + 2} = 3\sqrt{(e^{3t} + e^{-3t})^2} = 3(e^{3t} + e^{-3t}),$$

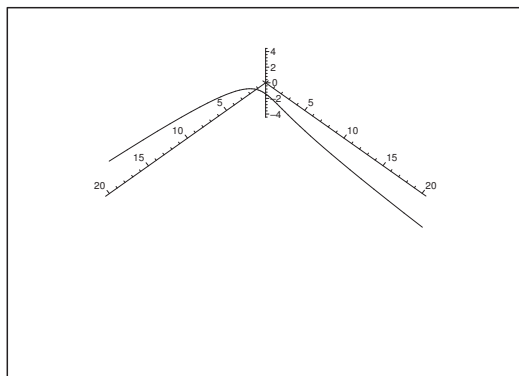
Figure 46: The curve \mathcal{K} .

and we get the arc length

$$\begin{aligned} \ell(\mathcal{K}) &= \int_{-1}^1 \|\mathbf{r}'(t)\| dt = \int_{-1}^1 3(e^{3t} + e^{-3t}) dt \\ &= 2 \int_0^1 3 \cdot 2 \cosh 3t dt = 4[\sinh 3t]_0^1 = 4 \sinh 3. \end{aligned}$$

Please click the advert







www.1calendar.dk

Example 3.8 A space curve \mathcal{K} is given by the parametric description

$$\mathbf{r}(t) = \left(\frac{1}{3}t^3 - t, \frac{1}{3}t^3 + t, t^2 \right), \quad t \in [-1, 1].$$

Find the arc length of \mathcal{K} .

A Arc length.

D Find $\|\mathbf{r}'(t)\|$.

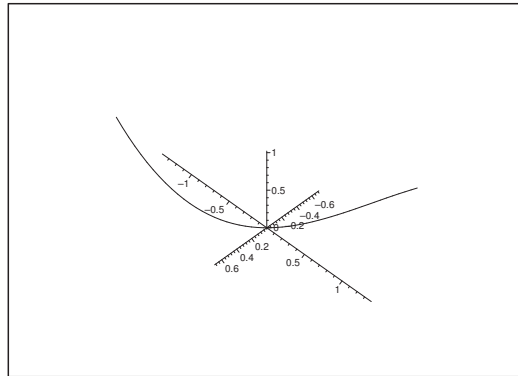

Figure 47: The curve \mathcal{K} .

I It follows from

$$\mathbf{r}'(t) = (t^2 - 1, t^2 + 1, 2t),$$

that

$$\|\mathbf{r}'(t)\|^2 = (t^2 - 1)^2 + (t^2 + 1)^2 + 4t^2 = 2t^4 + 2 + 4t^2 = 2(t^2 + 1)^2,$$

hence

$$\ell(\mathcal{K}) = \int_{-1}^1 \|\mathbf{r}'(t)\| dt = 2 \int_0^1 \sqrt{2}(t^2 + 1) dt = 2\sqrt{2} \left(\frac{1}{3} + 1 \right) = \frac{8\sqrt{2}}{3}.$$

Example 3.9 A space curve \mathcal{K} is given by the parametric description

$$\mathbf{r}(t) = (6t^2, 4\sqrt{2}t^3, 3t^4), \quad t \in [-1, 1].$$

Explain why the curve is symmetric with respect to the (X, Z) -plane. Then find the arc length of \mathcal{K} .

A Arc length.

D Replace t by $-t$. Then find $\mathbf{r}'(t)$.

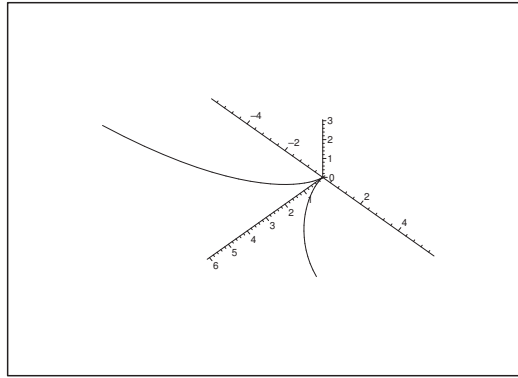
Figure 48: The curve \mathcal{K} .

I It follows from $\mathbf{r}(-t) = (6t^2, -4\sqrt{2}t^3, 3t^4)$, that the curve is symmetric with respect to the (X, Z) -plane.

From

$$\mathbf{r}'(t) = (12t, 12\sqrt{2}t^2, 12t^3) = 12t (1, \sqrt{2}t, t^2)$$

follows that

$$\|\mathbf{r}'(t)\| = 12|t| \cdot \sqrt{1 + 2t^2 + t^4} = 12|t| \cdot (1 + t^2).$$

Finally, when we exploit the symmetry above and put $u = t^2$, we find the arc length

$$\ell(\mathcal{K}) = 2 \int_0^1 \|\mathbf{r}'(t)\| dt = 2 \int_0^1 12t(1 + t^2) dt = 12 \int_0^1 (1 + u) du = 12 \left(1 + \frac{1}{2}\right) = 18.$$

Example 3.10 A space curve \mathcal{K} is given by the parametric description

$$\mathbf{r}(t) = (t + \sin t, \sqrt{2} \cos t, t - \sin t), \quad t \in [-1, 1].$$

1) Find a parametric description of the tangent of \mathcal{K} at the point corresponding to $t = 0$.

2) Compute the arc length of \mathcal{K} .

A Space curve.

D Follow the standard method.

I 1) As $\mathbf{r}(0) = (0, \sqrt{2}, 0)$, and

$$\mathbf{r}'(t) = (1 + \cos t, -\sqrt{2} \sin t, 1 - \cos t), \quad \mathbf{r}'(0) = (2, 0, 0),$$

it follows that a parametric description of the tangent of \mathcal{K} at $(0, \sqrt{2}, 0)$ is given by

$$\mathbf{x}(u) = (0, \sqrt{2}, 0) + (2u, 0, 0) = (2u, \sqrt{2}, 0), \quad u \in \mathbb{R}.$$

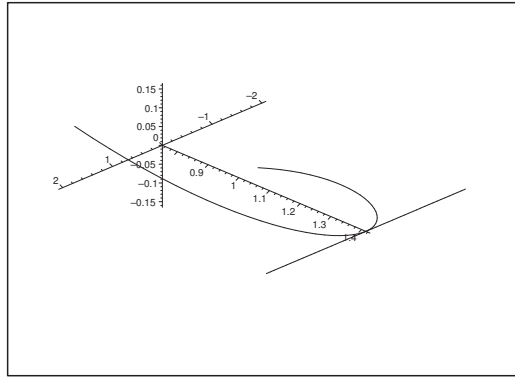

Figure 49: The curve \mathcal{K} and its tangent at $(0, \sqrt{2}, 0)$.

2) The arc length of \mathcal{K} is

$$\begin{aligned} \int_{-1}^1 \|\mathbf{r}'(t)\| dt &= \int_{-1}^1 \sqrt{(1 + \cos t)^2 + 2 \sin^2 t + (1 - \cos t)^2} dt \\ &= \int_{-1}^1 \sqrt{2 + 2 \cos^2 t + 2 \sin^2 t} dt = \int_{-1}^1 \sqrt{4} dt = 2 \cdot 2 = 4. \end{aligned}$$

Please click the advert

**Design your
own future at
MAN Diesel**

www.mandiesel.com

MAN Diesel – Powering the World



Download free books at BookBooN.com

4 Tangential line integrals

Example 4.1 Calculate in each of the following cases the tangential line integral

$$\int_{\mathcal{K}} \mathbf{V}(\mathbf{x}) \cdot d\mathbf{x}$$

of the vector field \mathbf{V} along the den plane curve \mathcal{K} . This curve will either be given by a parametric description or by an equation. First sketch the curve.

- 1) The vector field $\mathbf{V}(x, y) = (x^2 + y^2, x^2 - y^2)$ along the curve \mathcal{K} given by $y = 1 - |1 - x|$ for $x \in [0, 2]$.
- 2) The vector field $\mathbf{V}(x, y) = (x^2 - 2xy, y^2 - 2xy)$ along the curve \mathcal{K} given by $y = x^2$ for $x \in [-1, 1]$.
- 3) The vector field $\mathbf{V}(x, y) = (2a - y, x)$ along the curve \mathcal{K} given by $\mathbf{r}(t) = a(t - \sin t, 1 - \cos t)$ for $t \in [0, 2\pi]$.
- 4) The vector field $\mathbf{V}(x, y) = \left(\frac{x + y}{x^2 + y^2}, \frac{y - x}{x^2 + y^2} \right)$ along the curve \mathcal{K} given by $x^2 + y^2 = a^2$ and run through in the positive orientation of the plane.
- 5) The vector field $\mathbf{V}(x, y) = (x^2 - y^2, -(x + y))$ along the curve \mathcal{K} given by $\mathbf{r}(t) = (a \cos t, b \sin t)$ for $t \in \left[0, \frac{\pi}{2}\right]$.
- 6) The vector field $\mathbf{V}(x, y) = (x^2 - y^2, -(x + y))$ along the curve \mathcal{K} given by $\mathbf{r}(t) = (a(1 - t), bt)$ for $t \in [0, 1]$.
- 7) The vector field $\mathbf{V}(x, y) = (-y^3, x^3)$ along the curve \mathcal{K} given by $\mathbf{r}(t) = (1 + \cos t, \sin t)$ for $t \in \left[\frac{\pi}{2}, \pi\right]$.
- 8) The vector field $\mathbf{V}(x, y) = \left(-y^2, a^2 \sinh \frac{x}{a}\right)$ along the curve \mathcal{K} given by $y = a \cosh \frac{x}{a}$ for $x \in [a, 2a]$.

A Tangential line integrals.

D First sketch the curve. Then compute the tangential line integral.

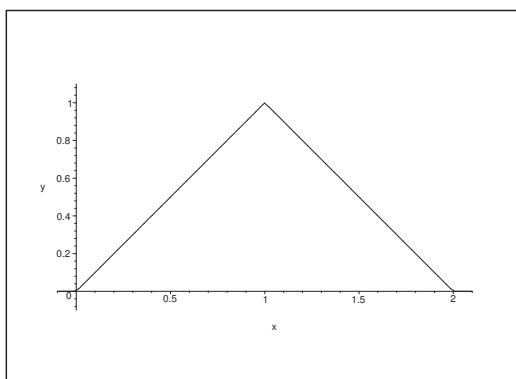

Figure 50: The curve \mathcal{K} of **Example 4.1.1**.

I 1) Here the parametric description of the curve can also be written

$$y = \begin{cases} x & \text{for } x \in [0, 1], \\ 2 - x & \text{for } x \in [1, 2]. \end{cases}$$

Please click the advert

Student Discounts + Student Events + Money Saving Advice = Happy Days!

wealthystudent.co.uk

Download free books at BookBooN.com

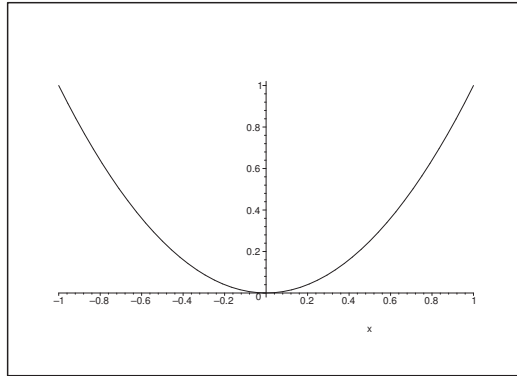
Figure 51: The curve \mathcal{K} of **Example 4.1.2**.

This gives the following computation of the tangential line integral

$$\begin{aligned}
 \int_{\mathcal{K}} \mathbf{V}(\mathbf{x}) \cdot d\mathbf{x} &= \int_{\mathcal{K}} \{(x^2 + y^2) dx + (x^2 - y^2) dy\} \\
 &= \int_0^1 \{(x^2 + x^2) dx + (x^2 - x^2) dx\} \\
 &\quad + \int_1^2 \{(x^2 + (2-x)^2) dx + (x^2 - (2-x)^2)(-dx)\} \\
 &= \int_0^1 2x^2 dx + \int_1^2 2(2-x)^2 dx = \frac{2}{3} [x^3]_0^1 + \frac{2}{3} [(x-2)^3]_1^2 \\
 &= \frac{2}{3} + \frac{2}{3} = \frac{4}{3}.
 \end{aligned}$$

2) Here

$$\begin{aligned}
 \int_{\mathcal{K}} \mathbf{V}(\mathbf{x}) \cdot d\mathbf{x} &= \int_{\mathcal{K}} \{(x^2 - 2xy) dx + (y^2 - 2xy) dy\} \\
 &= \int_{-1}^1 \{(x^2 - 2x^3) dx + (x^4 - 2x^3) \cdot 2x dx\} \\
 &= \int_{-1}^1 (x^2 - 2x^3 + 2x^5 - 4x^4) dx \\
 &= \int_{-1}^1 (x^2 - 4x^4) dx + 0 = 2 \left[\frac{1}{3} x^3 - \frac{4}{5} x^5 \right]_0^1 \\
 &= 2 \left(\frac{1}{3} - \frac{4}{5} \right) = \frac{2}{15} (5 - 12) = -\frac{14}{15}.
 \end{aligned}$$

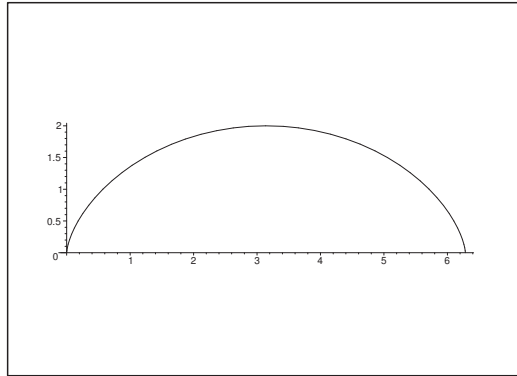
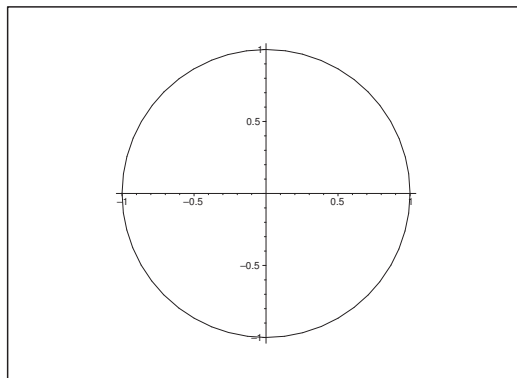
Figure 52: The curve \mathcal{K} of **Example 4.1.3** for $a = 1$.Figure 53: The curve \mathcal{K} of **Example 4.1.4** for $a = 1$.

3) Similarly we get

$$\begin{aligned}
 \int_{\mathcal{K}} \mathbf{V}(\mathbf{x}) \cdot d\mathbf{x} &= \int_{\mathcal{K}} \{(2a - y) dx + x dy\} \\
 &= \int_0^{2\pi} \{(2a - a(1 - \cos t))a(1 - \cos t) + a(t - \sin t)a \sin t\} dt \\
 &= a^2 \int_0^{2\pi} \{(1 + \cos t)(1 - \cos t) + (t - \sin t) \sin t\} dt \\
 &= a^2 \int_0^{2\pi} \{1 - \cos^2 t + t \sin t - \sin^2 t\} dt = a^2 \int_0^{2\pi} t \sin t dt \\
 &= a^2 [-t \cos t + \sin t]_0^{2\pi} = -2\pi a^2.
 \end{aligned}$$

4) We split the curve \mathcal{K} into two pieces, $\mathcal{K} = \mathcal{K}_1 + \mathcal{K}_2$, where \mathcal{K}_1 lies in the upper half plane, and \mathcal{K}_2 lies in the lower half plane, i.e. $y > 0$ inside \mathcal{K}_1 , and $y < 0$ inside \mathcal{K}_2 . Then we get the

tangential line integral

$$\begin{aligned}
 \int_{\mathcal{K}} \mathbf{V}(\mathbf{x}) \cdot d\mathbf{x} &= \int_{\mathcal{K}} \left(\frac{x+y}{x^2+y^2} dx + \frac{y-x}{x^2+y^2} dy \right) \\
 &= \int_{\mathcal{K}} \frac{1}{x^2+y^2} \frac{1}{2} d(x^2+y^2) + \int_{\mathcal{K}} \frac{1}{x^2+y^2} (y dx - x dy) \\
 &= \int_{\mathcal{K}} \frac{1}{2} d \ln(x^2+y^2) + \int_{\mathcal{K}_1} \frac{1}{1+\left(\frac{x}{y}\right)^2} \left(\frac{1}{y} dx + x \left(-\frac{1}{y^2}\right) dy \right) \\
 &\quad + \int_{\mathcal{K}_2} \frac{1}{1+\left(\frac{x}{y}\right)^2} \left(\frac{1}{y} dx + x \left(-\frac{1}{y^2}\right) dy \right) \\
 &= 0 + \int_{\mathcal{K}_1} \frac{1}{1+\left(\frac{x}{y}\right)^2} d\left(\frac{x}{y}\right) + \int_{\mathcal{K}_2} \frac{1}{1+\left(\frac{x}{y}\right)^2} d\left(\frac{x}{y}\right) \\
 &= \int_{\mathcal{K}_1} d\text{Arctan}\left(\frac{x}{y}\right) + \int_{\mathcal{K}_2} d\text{Arctan}\left(\frac{x}{y}\right) \\
 &= [\text{Arctan } t]_{+\infty}^{-\infty} + [\text{Arctan } t]_{+\infty}^{-\infty} = -\pi - \pi = -2\pi.
 \end{aligned}$$

WHAT'S MISSING IN THIS EQUATION?

You could be one of our future talents

MAERSK INTERNATIONAL TECHNOLOGY & SCIENCE PROGRAMME

Are you about to graduate as an **engineer** or **geoscientist**? Or have you already graduated?
If so, there may be an exciting future for you with A.P. Moller - Maersk.



MAERSK

www.maersk.com/mitas

Please click the advert

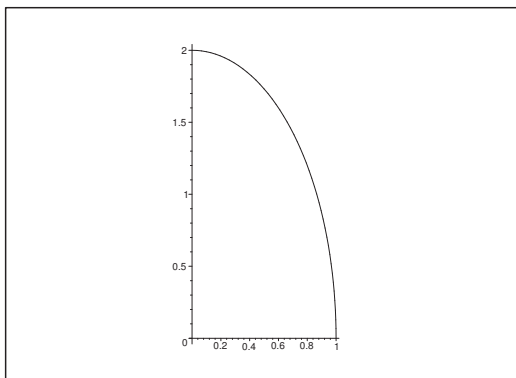

Figure 54: The curve \mathcal{K} of **Example 4.1.5** for $a = 1$ and $b = 2$.

ALTERNATIVELY we get by using the parametric description

$$(x, y) = a(\cos t, \sin t), \quad t \in [0, 2\pi],$$

that

$$\begin{aligned} \int_{\mathcal{K}} \mathbf{V}(\mathbf{x}) \cdot d\mathbf{x} &= \int_{\mathcal{K}} \left(\frac{x+y}{x^2+y^2} dx + \frac{y-x}{x^2+y^2} dy \right) \\ &= \int_0^{2\pi} \frac{a^2}{a^2} \{ (\cos t + \sin t)(-\sin t) + (\sin t - \cos t) \cos t \} dt \\ &= \int_0^{2\pi} \{ -\cos t \cdot \sin t - \sin^2 t + \cos t \cdot \sin t - \cos^2 t \} dt \\ &= - \int_0^{2\pi} dt = -2\pi. \end{aligned}$$

5) Here

$$\begin{aligned} \int_{\mathcal{K}} \mathbf{V}(\mathbf{x}) \cdot d\mathbf{x} &= \int_{\mathcal{K}} \{ (x^2 - y^2) dx - (x + y) dy \} \\ &= \int_0^{\frac{\pi}{2}} \{ (a^2 \cos^2 t - b^2 \sin^2 t)(-a \sin t) - (a \cos t + b \sin t) b \cos t \} dt \\ &= \int_0^{\frac{\pi}{2}} \{ -a[(a^2 + b^2) \cos^2 t - b^2] \sin t - ab \cos^2 t - b \sin t \cos t \} dt \\ &= \left[+a(a^2 + b^2) \frac{1}{3} \cos^3 t - ab^2 \cos t - \frac{ab}{2} (t + \frac{1}{2} \sin 2t) - \frac{1}{2} b^2 \sin^2 t \right]_0^{\frac{\pi}{2}} \\ &= -\frac{ab}{2} \cdot \frac{\pi}{2} - \frac{b^2}{2} - \frac{a(a^2 + b^2)}{3} + ab^2 = \frac{a}{3}(2b^2 - a^2) - \frac{b}{4}(2b + a\pi). \end{aligned}$$

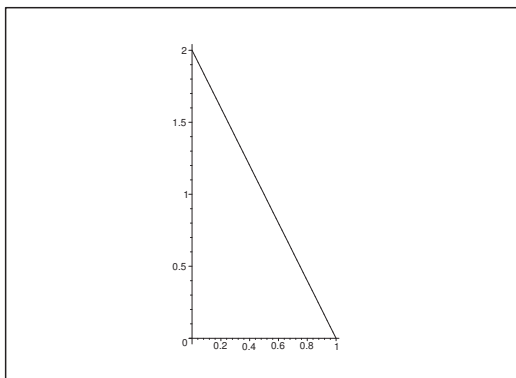
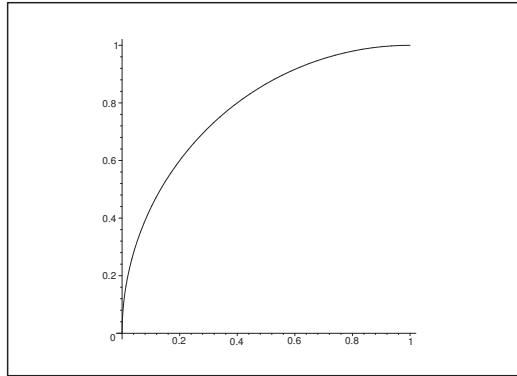

Figure 55: The curve \mathcal{K} of **Example 4.1.6** for $a = 1$ and $b = 2$.

6) Here

$$\begin{aligned}
 \int_{\mathcal{V}} \mathbf{V}(\mathbf{x}) \cdot d\mathbf{x} &= \int_{\mathcal{K}} \{(x^2 - y^2)dx - (x + y)dy\} \\
 &= \int_0^1 \{[a^2(1-t)^2 - b^2t^2](-a) - [a - at + bt] \cdot b\} dt \\
 &= \int_0^1 \{-a^3(t-1)^2 + ab^2t^2 + b(a-b)t - ab\} dt \\
 &= \left[-\frac{a^3}{3}(t-1)^3 + \frac{ab^2}{3}t^3 + \frac{1}{2}b(a-b)t^2 - abt \right]_0^1 \\
 &= \frac{ab^2}{3} + \frac{1}{2}(a-b)b - ab - \frac{a^3}{3} \\
 &= \frac{a}{3}(b^2 - a^2) - \frac{b}{2}(a+b).
 \end{aligned}$$

REMARK. The vector field $\mathbf{V}(\mathbf{x})$ is identical to that in **Example 4.1.5** and in **Example 4.1.6**. Furthermore, the curves of these two examples have the same initial point and end point. Nevertheless the two tangential line integrals give different results. We shall later be interested in those vector fields $\mathbf{V}(\mathbf{x})$, for which the tangential line integral *only* depends on the initial and end points of the curve \mathcal{K} . (In Physics such vector fields correspond to the so-called conservative fields.) We have here an example in which this ideal property is *not* satisfied. \diamond

Figure 56: The curve \mathcal{K} of **Example 4.1.7**.

7) We get

$$\begin{aligned}
 \int_{\mathcal{K}} \mathbf{V}(\mathbf{x}) \cdot d\mathbf{x} &= \int_{\mathcal{K}} \{-y^3 dx + x^3 dy\} \\
 &= \int_{\frac{\pi}{2}}^{\pi} \{-\sin^3 t \cdot (-\sin t) + (1 + \cos t)^3 \cos t\} dt \\
 &= \int_{\frac{\pi}{2}}^{\pi} \{\sin^4 t + \cos t + 3 \cos^2 t + 3 \cos^3 t + \cos^4 t\} dt \\
 &= \int_{\frac{\pi}{2}}^{\pi} \left\{ \sin^4 t + \cos^4 t + \left(2 \cos^2 t \cdot \sin^2 t - \frac{1}{2} \sin^2 2t \right) + \cos t + \frac{3}{2} + \frac{3}{2} \cos 2t + 3 \cos^3 t \right\} dt \\
 &= \int_{\frac{\pi}{2}}^{\pi} \left\{ (\sin^2 t + \cos^2 t)^2 - \frac{1}{4} + \frac{1}{4} \cos 4t + \cos t + \frac{3}{2} \cos 2t + 3 \cos t - 3 \sin^2 t \cos t \right\} dt \\
 &= \left[t - \frac{t}{4} + \frac{1}{16} \sin 4t + \sin t + \frac{3}{2} t + \frac{3}{4} \sin 2t + 3 \sin t - \sin^3 t \right]_{\frac{\pi}{2}}^{\pi} \\
 &= \left(1 - \frac{1}{4} + \frac{3}{2} \right) \frac{\pi}{2} - 4 + 1 = \frac{9\pi}{8} - 3.
 \end{aligned}$$

8) We get

$$\begin{aligned}
 \int_{\mathcal{K}} \mathbf{V}(\mathbf{x}) \cdot d\mathbf{x} &= \int_{\mathcal{K}} \left\{ -y^2 dx + a^2 \sinh \frac{x}{a} dy \right\} \\
 &= \int_a^{2a} \left\{ -a^2 \cosh^2 \frac{x}{a} dx + a^2 \sinh \frac{x}{a} \cdot \sinh \frac{x}{a} dx \right\} \\
 &= -a^2 \int_a^{2a} \left\{ \cosh^2 \left(\frac{x}{a} \right) - \sinh^2 \left(\frac{x}{a} \right) \right\} dx = -a^3.
 \end{aligned}$$

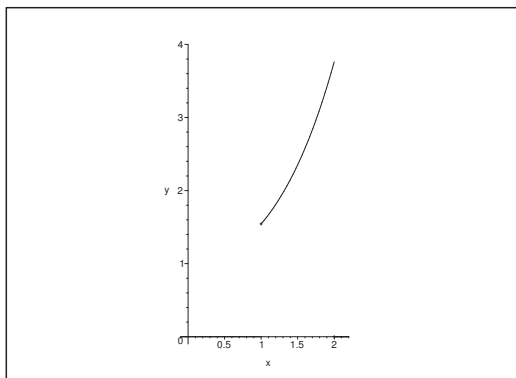

Figure 57: The curve \mathcal{K} of **Example 4.1.8** for $a = 1$.

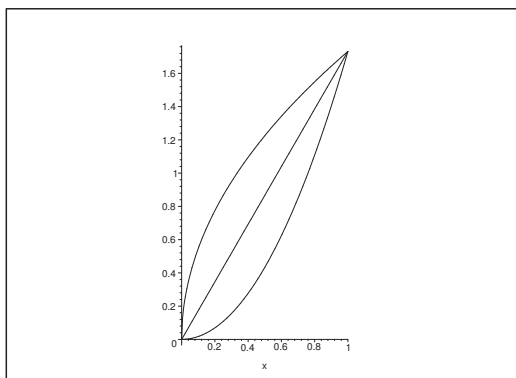

Figure 58: The curves $y = \sqrt{3x}$, $y = \sqrt{3}x$ and $y = \sqrt{3}x^2$.

Example 4.2 Compute the tangential line integral of the vector field

$$\mathbf{V}(x, y) = (2xy, x^6y^2)$$

along the curve \mathcal{K} give n by $y = ax^b$, $x \in [0, 1]$. Then find a such that the line integral becomes independent of b .

A Tangential line integral.

D Just use the standard method.

I We compute the line integral

$$\begin{aligned} \int_{\mathcal{K}} \mathbf{V}(x, y) \cdot d\mathbf{x} &= \int_{\mathcal{K}} (2xy \, dx + x^6y^2 \, dy) = \int_0^1 \{2x a x^b + x^6 a^2 x^{2b} \cdot ab x^{b-1}\} \, dx \\ &= \int_0^1 \{2a x^{b+1} + a^3 b x^{3b+5}\} \, dx = \frac{2a}{b+2} + \frac{a^3 b}{3(b+2)} = \frac{a(a^2b + 6)}{3(b+2)}. \end{aligned}$$

Assume that this result is independent of b . Then $b + 2$ must be proportional to $a^2b + 6$, so $a^2 = 3$.

According to the convention $a > 0$, thus $a = \sqrt{3}$. By choosing this a we get

$$\int_{\mathcal{K}} \mathbf{V}(x, y) \cdot d\mathbf{x} = \frac{\sqrt{3}(3b+6)}{3(b+2)} = \sqrt{3},$$

which is independent of b .

Please click the advert

CHALLENGE YOURSELF

WWW.STUDYINSWEDEN.SE

Si.
Swedish Institute

Today's job market values ambitious, innovative, perceptive team players. Swedish universities foster these qualities through a forward-thinking culture where you're close to the latest ideas and global trends.

Whatever your career goals may be, studying in Sweden will give you valuable skills and a competitive advantage for your future. www.studyinsweden.se

Download free books at BookBooN.com

Example 4.3 Compute in each of the following cases the tangential line integral

$$\int_{\mathcal{K}} \mathbf{V}(\mathbf{x}) \cdot d\mathbf{x}$$

of the vector field \mathbf{V} along the space curve \mathcal{K} , which is given by the parametric description

$$\mathcal{K} = \{\mathbf{x} \in \mathbb{R}^3 \mid \mathbf{x} = \mathbf{r}(t), t \in I\}.$$

1) The vector field is $\mathbf{V}(x, y, z) = (y^2 - z^2, 2yz, -x^2)$, and the curve \mathcal{K} is given by $\mathbf{r}(t) = (t, t^2, t^3)$ for $t \in I$.

2) The vector field is $\mathbf{V}(x, y, z) = \left(\frac{1}{x+z}, y+z, \frac{2}{x+y+z}\right)$, and the curve \mathcal{K} is given by $\mathbf{r}(t) = (t, t^2, t^3)$ for $t \in [1, 2]$.

3) The vector field is $\mathbf{V}(x, y, z) = (3x^2 - 6yz, 2y + 3xz, 1 - 4xyz^2)$, and the curve \mathcal{K} is given by $\mathbf{r}(t) = (t, t^2, t^3)$ for $t \in [0, 1]$.

4) The vector field is $\mathbf{V}(x, y, z) = (3x^2 - 6yz, 2y + 3xz, 1 - 4xyz^2)$, and the curve \mathcal{K} is given by $\mathbf{r}(t) = (t, t, t)$ for $t \in [0, 1]$.

5) The vector field is $\mathbf{V}(x, y, z) = (3x^2 - 6yz, 2y + 3xz, 1 - 4xyz^2)$, and the curve \mathcal{K} is given by

$$\mathbf{r}(t) = \begin{cases} (0, 0, t), & \text{for } t \in [0, 1], \\ (0, t - 1, 1), & \text{for } t \in [1, 2], \\ (t - 2, 1, 1), & \text{for } t \in [2, 3]. \end{cases}$$

6) The vector field is $\mathbf{V}(x, y, z) = (x, y, xz - y)$, and the curve \mathcal{K} is given by $\mathbf{r}(t) = (t, 2t, 4t)$ for $t \in [0, 1]$.

7) The vector field is $\mathbf{V}(x, y, z) = (2x + yz, 2y + xz, 2z + xy)$, and the curve \mathcal{K} is given by

$$\mathbf{r}(t) = (a(\cosh t) \cos t, a(\cosh t) \sin t, at) \quad \text{for } t \in [0, 2\pi].$$

8) The vector field is $\mathbf{V}(x, y, z) = (y^2 - z^2, 2yz, -x^2)$, and the curve \mathcal{K} is given by $\mathbf{r}(t) = (t, t, t)$ for $t \in [0, 1]$.

A Tangential line integrals in space.

D Insert the parametric descriptions and compute the tangential line integral. Notice that **Example 4.3.7** is a gradient field, so it is in this case possible to find the integral directly.

I 1) We get

$$\begin{aligned} \int_{\mathcal{K}} \mathbf{V}(\mathbf{x}) \cdot d\mathbf{x} &= \int_{\mathcal{K}} \{(y^2 - z^2)dx + 2yz dy - x^2 dz\} \\ &= \int_0^1 \{(t^4 - t^6) + 2t^2 \cdot t^3 \cdot 2t - t^3 \cdot 3t^2\} dt \\ &= \int_0^1 \{3t^6 - 2t^4\} dt = \frac{3}{7} - \frac{2}{5} = \frac{1}{35}. \end{aligned}$$

2) Here

$$\begin{aligned}
 \int_{\mathcal{K}} \mathbf{V}(\mathbf{x}) \cdot d\mathbf{x} &= \int_{\mathcal{K}} \left\{ \frac{1}{x+z} dx + (y+z) dy + \frac{2}{x+y+z} dz \right\} \\
 &= \int_1^2 \left\{ \frac{1}{t+t^3} + (t+t^3) + \frac{6t^2}{2t+t^3} \right\} dt \\
 &= \int_1^2 \left\{ \frac{1}{t} - \frac{t}{1+t^2} + \frac{6t}{2+t^2} + t+t^3 \right\} dt \\
 &= \left[\ln t - \frac{1}{2} \ln(1+t^2) + 3 \ln(2+t^2) + \frac{t^2}{2} + \frac{t^4}{4} \right]_1^2 \\
 &= \ln 2 - \frac{1}{2} \ln 5 + 3 \ln 6 - \frac{1}{2} \ln 2 - 3 \ln 3 + \frac{4}{2} + \frac{16}{4} - \frac{1}{2} - \frac{1}{4} \\
 &= \frac{9}{2} \ln 2 + \frac{1}{2} \ln 5 + \frac{21}{4} = \frac{21}{4} + \frac{1}{2} \ln \frac{512}{5}.
 \end{aligned}$$

3) First notice that for any curve,

$$\begin{aligned}
 \int_{\mathcal{K}} \mathbf{V}(\mathbf{x}) \cdot d\mathbf{x} &= \int_{\mathcal{K}} \{(3x^2 - 6yz)dx + (2y + 3xz)dy + (1 - 4xyz^2)dz\} \\
 (2) \quad &= \int_{\mathcal{K}} d(x^3 + y^2 + z) - \int_{\mathcal{K}} z\{6ydx - 3xdy + 4xyzdz\}.
 \end{aligned}$$

Such a rearrangement can also be used advantageously to **Example 4.3.3**, **Example 4.3.4** and **Example 4.3.5**.

When we apply (2), we get

$$\begin{aligned}
 \int_{\mathcal{K}} \mathbf{V}(\mathbf{x}) \cdot d(\mathbf{x}) &= [x^3 + y^2 + z]_{(0,0,0)}^{(1,1,1)} - \int_0^1 t^3 \{6t^2 - 3t \cdot 2t + t^6 \cdot 3t^2\} dt \\
 &= 3 - \int_0^1 12t^{11} dt = 3 - 1 = 2.
 \end{aligned}$$

ALTERNATIVELY, it follows by a direct insertion that

$$\begin{aligned}
 \int_{\mathcal{K}} \mathbf{V}(\mathbf{x}) \cdot d\mathbf{x} &= \int_{\mathcal{K}} \{(3x^2 - 6yz)dx + (2y + 3xz)dy + (1 - 4xyz^2)dz\} \\
 &= \int_0^1 \{(3t^2 - 6t^2 \cdot t^3) + (2t^2 + 3t \cdot t^3)2t + (1 - 4t \cdot t^2 \cdot t^6)3t^2\} dt \\
 &= \int_0^1 \{3t^2 - 6t^5 + 4t^3 + 6t^5 + 3t^2 - 12t^{11}\} dt \\
 &= \int_0^1 (6t^2 + 4t^3 - 12t^{11}) dt = [2t^3 + t^4 - t^{12}]_0^1 = 2.
 \end{aligned}$$

4) The vector field is the same as in **Example 4.3.3**. Then we get by (2),

$$\begin{aligned}
 \int_{\mathcal{K}} \mathbf{V}(\mathbf{x}) \cdot d\mathbf{x} &= [x^3 + y^2 + z]_{(0,0,0)}^{(1,1,1)} - \int_0^1 (6t^2 - 3t^2 + 4t^4) dt \\
 &= 3 - \int_0^1 (3t^2 + 4t^4) dt = 3 - 1 - \frac{4}{5} = \frac{6}{5}.
 \end{aligned}$$

ALTERNATIVELY, it follows by a direct insertion that

$$\begin{aligned}\int_{\mathcal{K}} \mathbf{V}(\mathbf{x}) \cdot d\mathbf{x} &= \int_0^1 \{(3t^2 - 6t^2) + (2t + 3t^2) + 1 - 4t^4\} dt \\ &= \int_0^1 (1 + 2t - 4t^4) dt = 1 + 1 - \frac{4}{5} = \frac{6}{5}.\end{aligned}$$

- 5) The vector field is the same as in **Example 4.3.3**. When we apply (2) and just check that $\mathbf{r}(t)$ is a continuous curve, we get

$$\begin{aligned}\int_{\mathcal{K}} \mathbf{V}(\mathbf{x}) \cdot d\mathbf{x} &= [x^3 + y^2 + z]_{(0,0,0)}^{(1,1,1)} - \int_{\mathcal{K}} z\{6ydx - 3xdy + 4xyzdx\} \\ &= 3 - \int_0^1 0 dt - \int_1^2 +20 dt - \int_2^3 1 \cdot 6 dt = 3 - 6 = -3.\end{aligned}$$

ALTERNATIVELY, it follows by direct insertion that

$$\begin{aligned}\int_{\mathcal{K}} \mathbf{V}(\mathbf{x}) \cdot d\mathbf{x} &= \int_{\mathcal{K}} \{(3x^2 - 6yz)dx + (2y + 3xz)dy + (1 - 4xyz^2)dz\} \\ &= \int_0^1 (1 - 4 \cdot 0) dt + \int_1^2 \{2(t-1) + 0\} dt + \int_2^3 \{3(t-2)^2 - 6\} dt \\ &= [t]_0^1 + 2 \left[\frac{1}{2} (t-1)^2 \right]_1^2 + 3 \left[\frac{1}{3} (t-2)^3 - 2t \right]_2^3 \\ &= 1 + 1 + 1 - 3 \cdot 2 \cdot 3 + 3 \cdot 2 \cdot 2 = 3(1 - 6 + 4) = -3.\end{aligned}$$

- 6) Here we get by insertion,

$$\begin{aligned}\int_{\mathcal{K}} \mathbf{V}(\mathbf{x}) \cdot d\mathbf{x} &= \int_{\mathcal{K}} \{x dx + y dy + (xz - y) dz\} \\ &= \int_0^1 \{t + 2t \cdot 2 + (t \cdot 4t - 2t) \cdot 4\} dt \\ &= \int_0^1 (t + 4t + 16t^2 - 8t) dt = \int_0^1 (16t^2 - 3t) dt \\ &= \frac{16}{3} - \frac{3}{2} = \frac{32 - 9}{6} = \frac{23}{6}.\end{aligned}$$

- 7) It follows immediately that

$$\begin{aligned}\int_{\mathcal{K}} \mathbf{V}(\mathbf{x}) \cdot d\mathbf{x} &= \int_{\mathcal{K}} \{(2x + yz)dx + (2y + xz)dy + (2zxy)dz\} \\ &= \int_{\mathcal{K}} \{d(x^2 + y^2 + z^2) + (yzdx + xzdy + xydz)\} \\ &= \int_{\mathcal{K}} d(x^2 + y^2 + z^2 + xyz) = [x^2 + y^2 + z^2 + xyz]_{(x,y,z)=(a,0,0)}^{a(\cosh 2\pi, 0, 2\pi)} \\ &= a^2 \cosh^2 2\pi + 4a^2 \pi^2 - a^2 = a^2(4\pi^2 + \sinh^2 2\pi).\end{aligned}$$

ALTERNATIVELY, we get by the parametric description

$$\mathbf{r}(t) = a(\cosh t \cdot \cos t, \cosh t \cdot \sin t, t), \quad t \in [0, 2\pi],$$

that

$$\mathbf{r}'(t) = a(\sinh t \cdot \cos t - \cosh t \cdot \sin t, \sinh t \cdot \sin t + \cosh t \cdot \cos t, 1),$$

thus

$$\begin{aligned}
 \int_{\mathcal{K}} \mathbf{V}(\mathbf{x}) \cdot d\mathbf{x} &= \int_{\mathcal{K}} \{(2x + yz)dx + (2y + xz)dy + (2z + xy)dz\} \\
 &= \int_0^{2\pi} (2a \cosh t \cos t + a^2 t \cosh t \sin t) a (\sinh t \cos t - \cosh t \sin t) dt \\
 &\quad + \int_0^{2\pi} (2a \cosh t \sin t + a^2 \cosh t \cos t) a (\sinh t \sin t + \cosh t \cos t) dt \\
 &\quad + \int_0^{2\pi} (2at + a^2 \cosh^2 t \cdot \cos t \cdot \sin t) a dt \\
 &= a^2 \cdot (\dots) + a^3 \cdot (\dots).
 \end{aligned}$$

Then the easiest method is to reduce and use that

$$\cos t = \frac{1}{2} (e^{it} + e^{-it}), \quad \sin t = \frac{1}{2i} (e^{it} - e^{-it}),$$

and similarly for $\cosh t$ and $\sinh t$. We finally obtain the result by a partial integration.

Please click the advert

www.job.oticon.dk

oticon
PEOPLE FIRST

The variants above are somewhat sophisticated, so we proceed here by first calculating the coefficient of a^2 :

$$\begin{aligned} & \int_0^{2\pi} 2 \cosh t \cdot t (\sinh t \cdot \cos t - \cosh t \cdot \sin t) dt \\ & \quad + \int_0^{2\pi} 2 \cosh t \cdot \sin t (\sinh t \cdot \sin t + \cosh t \cdot \cos t) dt + \int_0^{2\pi} 2t dt \\ & = 2 \int_0^{2\pi} \cosh t \cdot \sinh t dt + \int_0^{2\pi} 2t dt = [\sinh^2 t + t^2]_0^{2\pi} = 4\pi^2 + \sinh^2 2\pi. \end{aligned}$$

Then we find the coefficient of a^3 :

$$\begin{aligned} & \int_0^{2\pi} t \{ \cosh t \sinh t \sin t \cos t - \cosh^2 t \sin^2 t \} dt \\ & \quad + \int_0^{2\pi} t \{ \cosh t \sinh t \sin t \cos t + \cosh^2 t \cos^2 t \} dt + \int_0^{2\pi} \cosh^2 t \cos t \sin t dt \\ & = \int_0^{2\pi} t (\cosh t \sinh t \sin 2t + \cosh^2 t \cos 2t) dt + \frac{1}{2} \int_0^{2\pi} \cosh^2 t \sin 2t dt. \end{aligned}$$

Notice that

$$\frac{d}{dt} \left\{ \frac{1}{2} \cosh^2 t \cdot \sin 2t \right\} = \cosh t \cdot \sinh t \cdot \sin 2t + \cosh^2 t \cdot \cos 2t,$$

so the whole expression can then be written

$$\begin{aligned} & \int_0^{2\pi} \left\{ t \frac{d}{dt} \left(\frac{1}{2} \cosh^2 t \sin 2t \right) + \frac{dt}{dt} \cdot \left(\frac{1}{2} \cosh^2 t \sin 2t \right) \right\} dt \\ & = \int_0^{2\pi} \frac{d}{dy} \left(\frac{t}{2} \cosh^2 t \sin 2t \right) dt = \left[\frac{t}{2} \cosh^2 t \cdot \sin 2t \right]_0^{2\pi} = 0. \end{aligned}$$

As a conclusion we get

$$\int_{\mathcal{K}} \mathbf{V}(\mathbf{x}) \cdot d\mathbf{x} = a^2(4\pi^2 + \sinh^2 2\pi) + 0 \cdot a^3 = a^2(4\pi^2 + \sinh^2 2\pi).$$

8) Here we get [cf. also **Example 4.3.1**, where the vector field is the same]

$$\begin{aligned} \int_{\mathcal{K}} \mathbf{V}(\mathbf{x}) \cdot d\mathbf{x} & = \int_{\mathcal{K}} \{ (y^2 - z^2) dx + 2yz dy - x^2 dz \} \\ & = \int_0^1 \{ (t^2 - t^2) + 2t^2 - t^2 \} dt = \int_0^1 t^2 dt = \frac{1}{3}. \end{aligned}$$

Example 4.4 Compute in each of the following cases the tangential line integral of the given vector field \mathbf{V} along the given curve \mathcal{K} .

1) The vector field is $\mathbf{V}(x, y) = (x + y, x - y)$, and the curve \mathcal{K} is the ellipse of centrum $(0, 0)$ and half axes a, b , run through in the positive orientation of the plane.

2) The vector field is $\mathbf{V}(x, y) = \left(\frac{1}{|x| + |y|}, \frac{1}{|x| + |y|} \right)$, and the curve \mathcal{K} is the square defined by its vertices

$$(1, 0), \quad (0, 1), \quad (-1, 0), \quad (0, -1),$$

in the positive orientation of the plane.

3) The vector field is $\mathbf{V}(x, y) = (x^2 - y, y^2 + x)$, and the curve \mathcal{K} is the line segment from $(0, 1)$ to $(1, 2)$.

4) The vector field is $\mathbf{V}(x, y) = (x^2 - y^2, y^2 + x)$, and the curve \mathcal{K} is the broken line from $(0, 1)$ over $(1, 1)$ to $(1, 2)$.

5) The vector field is $\mathbf{V}(x, y) = (x^2 - y, y^2 + x)$, and the curve \mathcal{K} is that part of the parabola of equation $y = 1 + x^2$, which has the initial point $(0, 1)$ and the end point $(1, 2)$.

6) The vector field is $\mathbf{V}(x, y, z) = (yz, xz, x(y + 1))$, and the curve \mathcal{K} is the triangle given by its vertices

$$(0, 0, 0), \quad (1, 1, 1), \quad (-1, 1, -1),$$

and run through in given sequence.

7) The vector field is $\mathbf{V}(x, y, z) = (\sin y, \sin z, \sin x)$, and the curve \mathcal{K} is the line segment from $(0, 0, 0)$ to (π, π, π) .

8) The vector field is $\mathbf{V}(x, y, z) = (z, x, -y)$, and the curve \mathcal{K} is the quarter circle from $(a, 0, 0)$ to $(0, 0, a)$ followed by another quarter circle from $(0, 0, a)$ to $(0, a, 0)$, both of centrum $(0, 0, 0)$.

A Tangential line integrals in the 2-dimensional and the 3-dimensional space.

D Sketch in the 2-dimensional case the curve \mathcal{K} . Then check if any part of $\mathbf{V}(\mathbf{x}) \cdot d\mathbf{x}$ can be sorted out as a total differential. Finally, insert the parametric description and compute.

I 1) As \mathcal{K} is a closed curve, we get

$$\int_{\mathcal{K}} \mathbf{V}(\mathbf{x}) \cdot d\mathbf{x} = \int_{\mathcal{K}} \{(x + y)dx + (x - y)dy\} = \int_{\mathcal{K}} d\left(\frac{1}{2}x^2 + xy - \frac{1}{2}y^2\right) = 0,$$

because $\mathbf{V} \cdot d\mathbf{x}$ is a total differential.

ALTERNATIVELY, \mathcal{K} has e.g. the parametric description

$$(x, y) = \mathbf{r}(t) = (a \cos t, b \sin t), \quad t \in [0, 2\pi],$$

thus

$$\mathbf{r}'(t) = (-a \sin t, b \cos t).$$

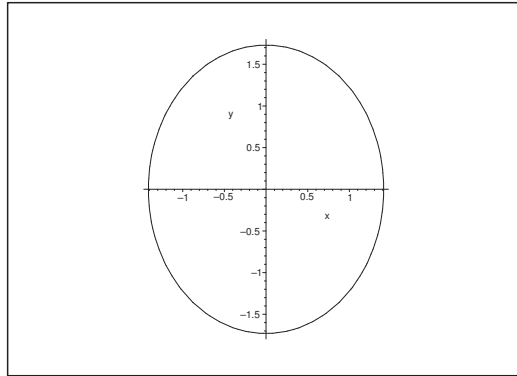
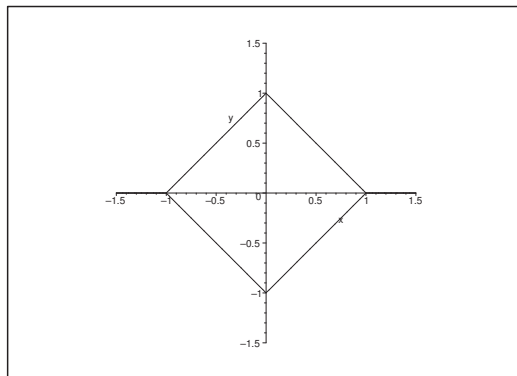
Figure 59: A possible curve \mathcal{K} in **Example 4.4.1**.Figure 60: The curve of **Example 4.4.2**.

Then by insertion,

$$\begin{aligned}
 \int_{\mathcal{K}} \mathbf{V} \cdot d\mathbf{x} &= \int_{\mathcal{K}} \{(x+y)dx + (x-y)dy\} \\
 &= \int_0^{2\pi} \{(a \cos t + b \sin t)(-a \sin t) + (a \cos t - b \sin t)b \cos t\} dt \\
 &= \int_0^{2\pi} \{-a^2 \cos t \sin t - ab \sin^2 t + ab \cos^2 t - b^2 \sin t \cos t\} dt \\
 &= \int_0^{2\pi} \left\{ ab \cos 2t - \frac{1}{2}(a^2 + b^2) \sin 2t \right\} dt = 0.
 \end{aligned}$$

2) Since $|x| + |y| = 1$ on \mathcal{K} , we have

$$\int_{\mathcal{K}} \mathbf{V} \cdot d\mathbf{x} = \int_{\mathcal{K}} \frac{1}{|x| + |y|} (dx + dy) = \int_{\mathcal{K}} 1 d(x+y) = 0.$$

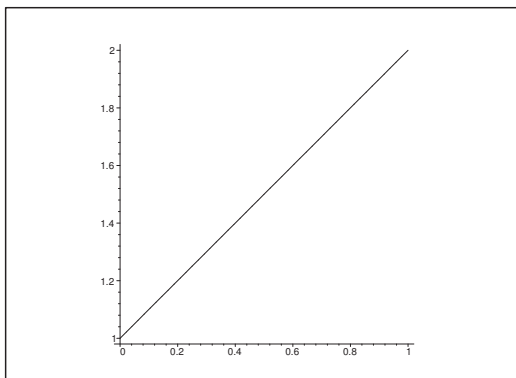

Figure 61: The curve \mathcal{K} of **Example 4.4.3**

ALTERNATIVELY, and more difficult we can use the parametric description of \mathcal{K} given by

$$\mathbf{r}(t) = \begin{cases} (1-t, t), & t \in [0, 1], \\ (1-t, 2-t), & t \in [1, 2], \\ (t-3, 2-t), & t \in [2, 3], \\ (t-3, t-4), & t \in [3, 4], \end{cases}$$

hence

$$\mathbf{r}'(t) = \begin{cases} (-1, 1), & t \in]0, 1[, \\ (-1, -1), & t \in]1, 2[, \\ (1, -1), & t \in]2, 3[, \\ (1, 1), & t \in]3, 4[. \end{cases}$$

Since $|x| + |y| = 1$ on \mathcal{K} , we get

$$\begin{aligned} \int_{\mathcal{K}} \mathbf{V} \cdot d\mathbf{x} &= \int_{\mathcal{K}} (dx + dy) = \int_0^1 (-1 + 1)dt + \int_1^2 (-1 - 1)dt + \int_2^3 (1 - 1)dt + \int_3^4 (1 + 1)dt \\ &= 0 - 2 + 0 + 2 = 0. \end{aligned}$$

3) First notice that

$$\begin{aligned} \int_{\mathcal{K}} \mathbf{V} \cdot d\mathbf{x} &= \int_{\mathcal{K}} \{(x^2 - y)dx + (y^2 + x)dy\} = \frac{1}{3} \int_{\mathcal{K}} d(x^3 + y^3) + \int_{\mathcal{K}} (-y dx + x dy) \\ &= \frac{1}{3}(8 + 1 - 1) + \int_{\mathcal{K}} (-y dx + x dy), \end{aligned}$$

so

$$(3) \int_{\mathcal{K}} \mathbf{V} \cdot d\mathbf{x} = \frac{8}{3} + \int_{\mathcal{K}} (-y dx + x dy)$$

$$(4) = \int_{\mathcal{K}} \{(x^2 - y)dx + (y^2 + x)dy\}.$$

Now we compute **Example 4.4.3**, **Example 4.4.4** and **Example 4.4.5** in the two variants corresponding to (3) and (4), respectively.

A parametric description of \mathcal{K} is e.g.

$$\mathbf{r}(t) = (t, 1 + t), \quad t \in [0, 1],$$

and accordingly, $\mathbf{r}'(t) = (1, 1)$.

Please click the advert

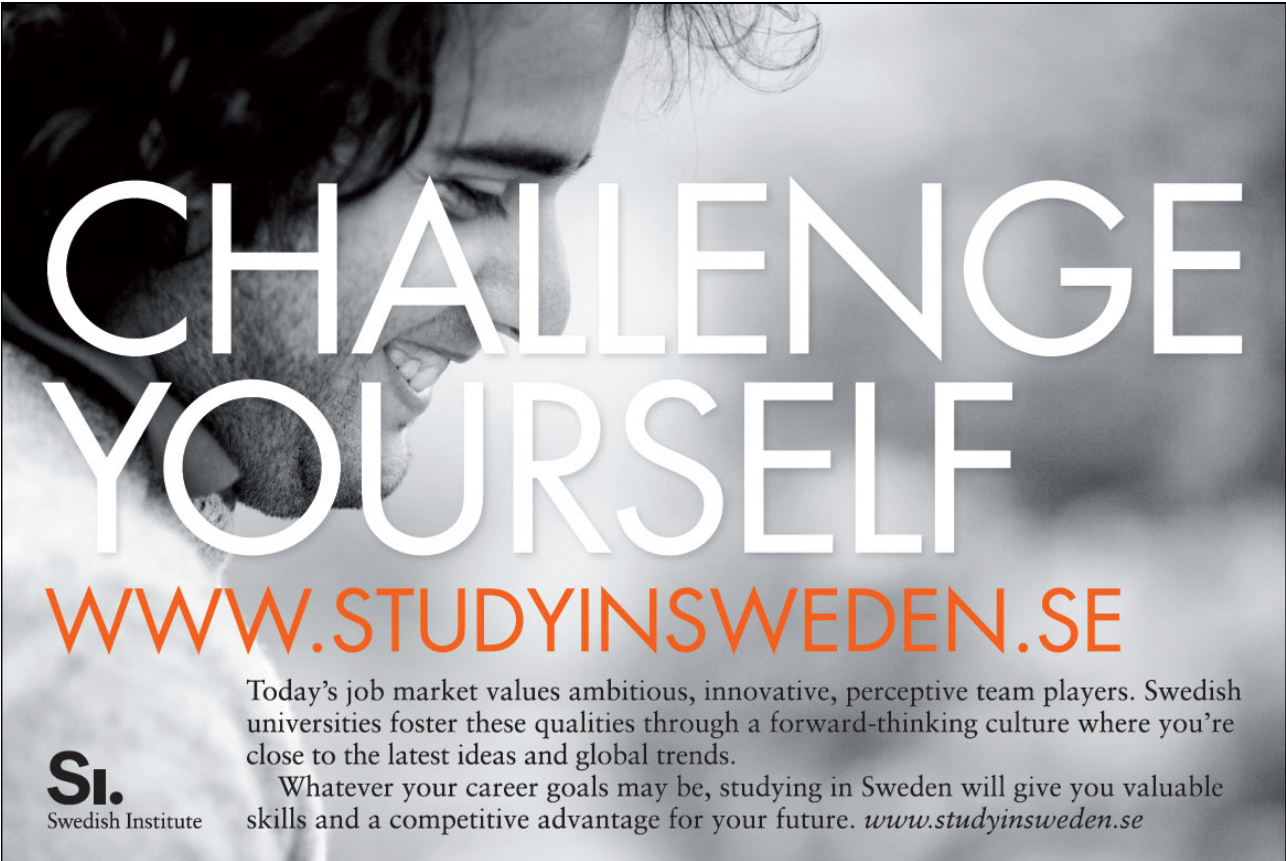

CHALLENGE YOURSELF

WWW.STUDYINSWEDEN.SE

Today's job market values ambitious, innovative, perceptive team players. Swedish universities foster these qualities through a forward-thinking culture where you're close to the latest ideas and global trends.

Whatever your career goals may be, studying in Sweden will give you valuable skills and a competitive advantage for your future. www.studyinsweden.se

Si.
Swedish Institute

Download free books at BookBooN.com

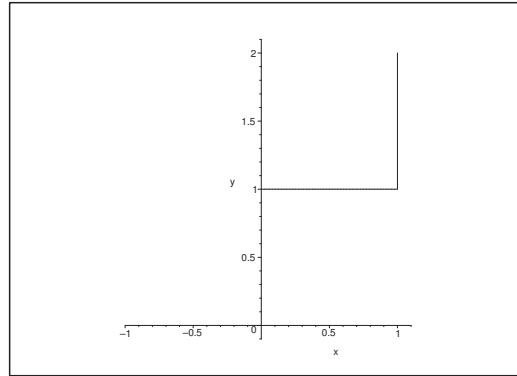
Figure 62: The curve \mathcal{K} of **Example 4.4.4**.

Then by (3),

$$\int_{\mathcal{K}} \mathbf{V} \cdot d\mathbf{x} = \frac{8}{3} + \int_0^1 \{-(1+t) + t\} dt = \frac{8}{3} - 1 = \frac{5}{3}.$$

ALTERNATIVELY, we get by (4) that

$$\begin{aligned} \int_{\mathcal{K}} \mathbf{V} \cdot d\mathbf{x} &= \int_0^1 \{t^2 - (1+t) + (1+t)^2 + t\} dt = \int_0^1 \{(1+t)^2 + t^2 - 1\} dt \\ &= \left[\frac{1}{3}(1+t)^3 + \frac{1}{3}t^3 - t \right]_0^1 = \frac{8+1-1}{3} - 1 = \frac{5}{3}. \end{aligned}$$

4) It follows from (3) that

$$\int_{\mathcal{K}} \mathbf{V} \cdot d\mathbf{x} = \frac{8}{3} + \int_0^1 (-1) dx + \int_1^2 1 dy = \frac{8}{3} - 1 + 1 = \frac{8}{3}.$$

ALTERNATIVELY, we get by (4),

$$\begin{aligned} \int_{\mathcal{K}} \mathbf{V} \cdot d\mathbf{x} &= \int_0^1 (x^2 - 1) dx + \int_1^2 (y^2 + 1) dy = \left[\frac{1}{3}x^3 - x \right]_0^1 + \left[\frac{1}{3}y^3 + y \right]_1^2 \\ &= \frac{1}{3} - 1 + \frac{8}{3} + 2 - \frac{1}{3} - 1 = \frac{8}{3}. \end{aligned}$$

5) By (3),

$$\begin{aligned} \int_{\mathcal{K}} \mathbf{V} \cdot d\mathbf{x} &= \frac{8}{3} + \int_0^1 \{(-1 - x^2) + x \cdot 2x\} dx \\ &= \frac{8}{3} + \int_0^1 (x^2 - 1) dx = \frac{8}{3} + \left[\frac{1}{3}x^3 - x \right]_0^1 = \frac{8}{3} + \frac{1}{3} - 1 = 2. \end{aligned}$$

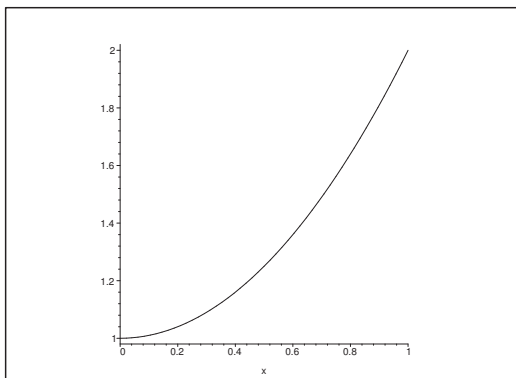

Figure 63: The curve \mathcal{K} of **Example 4.4.5**.

ALTERNATIVELY, by (4),

$$\begin{aligned} \int_{\mathcal{K}} \mathbf{V} \cdot d\mathbf{x} &= \int_{\mathcal{K}} \{x^2 - x^2 - 1 + [(x^2 + 1)^2 + x] \cdot 2x\} dx \\ &= \int_{\mathcal{K}} \{2x^5 + 4x^3 + 2x^2 + 2x - 1\} dx \\ &= \left[\frac{1}{3} x^6 + x^3 + \frac{2}{3} x^3 + x^2 - x \right]_0^1 = \frac{1}{3} + 1 + \frac{2}{3} + 1 - 1 = 2. \end{aligned}$$

6) Here a parametric description is e.g. given by

$$\mathbf{r}(t) = \begin{cases} (t, t, t), & t \in [0, 1], \\ (3 - 2t, 1, 3 - 2t), & t \in [1, 2], \\ (t - 3, -t + 3, t - 3), & t \in [2, 3], \end{cases}$$

hence

$$\mathbf{r}'(t) = \begin{cases} (1, 1, 1), & t \in]0, 1[, \\ (-2, 0, -2), & t \in]1, 2[, \\ (1, -1, 1), & t \in]2, 3[. \end{cases}$$

FIRST VARIANT. We get by direct insertion,

$$\begin{aligned} \int_{\mathcal{K}} \mathbf{V} \cdot d\mathbf{x} &= \int_{\mathcal{K}} \{yz \, dx + xz \, dy + x(y + 1)dz\} \\ &= \int_0^1 (t^2 + t^2 + t^2 + t) dt + \int_1^2 \{1 \cdot (3 - 2t) \cdot (-2) + (3 - 2t) \cdot 2 \cdot (-2)\} dt \\ &\quad + \int_2^3 \{(-t + 3)(t - 3) \cdot 1 + (t - 3)^2 \cdot (-1) + (t - 3)(-t + 3) \cdot 1 + t - 3\} dt \\ &= \int_0^1 (3t^2 + t) dt - 6 \int_1^2 (3 - 2t) dt - \int_2^3 \{3(t - 3)^2 - (t - 3)\} dt \\ &= \left[t^3 + \frac{1}{2} t^2 \right]_0^1 + 6 [t^2 - 3t]_1^2 - \left[(t - 3)^3 - \frac{1}{2}(t - 3)^2 \right]_2^3 \\ &= 1 + \frac{1}{2} + 6(4 - 6 - 1 + 3) + \left(-1 - \frac{1}{2} \right) = 0. \end{aligned}$$

2. variant. Reduction by removing a total differential.

As

$$\mathbf{V} \cdot d\mathbf{x} = yz \, dx + xz \, dy + xy \, dz + x \, dz = d(xyz) + x \, dz,$$

and as \mathcal{K} is a closed curve, we have $\int_{\mathcal{K}} d(xyz) = 0$, so the calculations are simplified by removing $d(xyz)$:

$$\begin{aligned} \int_{\mathcal{K}} \mathbf{V} \cdot d\mathbf{x} &= \int_{\mathcal{K}} d(xyz) + \int_{\mathcal{K}} x \, dz = 0 + \int_{\mathcal{K}} x \, dz \\ &= \int_0^1 t \, dt + \int_1^2 (3-2t) \cdot (-2) \, dt + \int_2^3 (t-3) \, dt \\ &= \left[\frac{1}{2} t^2 \right]_0^1 + \int_1^2 (4t-6) \, dt + \left[\frac{1}{2} (t-3)^2 \right]_2^3 \\ &= \frac{1}{2} + [2t^2 - 6t]_1^2 - \frac{1}{2} = 8 - 12 - 2 + 6 = 0. \end{aligned}$$

REMARK. The expressions will be even simpler, if we do not insist on that the parametric intervals $[0, 1]$, $[1, 2]$, $[2, 3]$ should follow each other. Instead one can split \mathcal{K} into three subcurves

$$\begin{aligned} \mathcal{K}_1: \quad \mathbf{r}_1(t) &= (t, t, t), & t &\in [0, 1], \\ \mathcal{K}_2: \quad \mathbf{r}_2(t) &= (1-2t, 1, 1-2t), & t &\in [0, 1], \\ \mathcal{K}_3: \quad \mathbf{r}_3(t) &= (t-1, 1-t, t-1), & t &\in [0, 1], \end{aligned}$$

where

$$\begin{aligned} \mathcal{K}_1: \quad \mathbf{r}'_1(t) &= (1, 1, 1), & t &\in]0, 1[; \\ \mathcal{K}_2: \quad \mathbf{r}'_2(t) &= (-2, 0, 2), & t &\in]0, 1[; \\ \mathcal{K}_3: \quad \mathbf{r}'_3(t) &= (1, -1, 1). & t &\in]0, 1[. \end{aligned}$$

We obtain that the three line integrals can be joined like in the second variant above:

$$\begin{aligned} \int_{\mathcal{K}} \mathbf{V} \cdot d\mathbf{x} &= \dots = \int_{\mathcal{K}} x \, dz = \int_{\mathcal{K}_1} x \, dz + \int_{\mathcal{K}_2} x \, dz + \int_{\mathcal{K}_3} x \, dz \\ &= \int_0^1 t \, dt + \int_0^1 (1-2t) \cdot (-2) \, dt + \int_0^1 (t-1) \, dt \\ &= 3 \int_0^1 (2t-1) \, dt = 3 [t^2 - t]_0^1 = 0. \quad \diamond \end{aligned}$$

7) The most obvious parametric description is here

$$\mathbf{r}(t) = t(1, 1, 1), \quad \text{med } \mathbf{r}'(t) = (1, 1, 1), \quad t \in [0, \pi].$$

Thus we can put $x = y = z = t$ everywhere. Then

$$\int_{\mathcal{K}} \mathbf{V} \cdot d\mathbf{x} = \int_{\mathcal{K}} \{\sin y \, dx + \sin z \, dy + \sin x \, dz\} = \int_0^\pi 3 \sin t \, dt = [-3 \cos t]_0^\pi = 6.$$

8) If we call the two curve segments for \mathcal{K}_1 and \mathcal{K}_2 , then the most obvious parametric description is

$$\begin{aligned} \mathcal{K}_1: \quad a(\cos t, 0, \sin t), & \quad t \in \left[0, \frac{\pi}{2}\right], \\ \mathcal{K}_2: \quad a(0, \sin t, \cos t), & \quad t \in \left[0, \frac{\pi}{2}\right]. \end{aligned}$$

Then by insertion,

$$\begin{aligned}
 \int_{\mathcal{K}} \mathbf{V} \cdot d\mathbf{x} &= \int_{\mathcal{K}} (z dx + x dy - y dz) \\
 &= a^2 \int_0^{\frac{\pi}{2}} (\sin t \cdot (-\sin t)) dt + a^2 \int_0^{\frac{\pi}{2}} (-\sin t) \cdot (-\sin t) dt \\
 &= -a^2 \int_0^{\frac{\pi}{2}} \sin^2 t dt + a^2 \int_0^{\frac{\pi}{2}} \sin^2 t dt = 0.
 \end{aligned}$$

Please click the advert

Turning a challenge into a learning curve. Just another day at the office for a high performer.

Accenture Boot Camp – your toughest test yet

Choose Accenture for a career where the variety of opportunities and challenges allows you to make a difference every day. A place where you can develop your potential and grow professionally, working alongside talented colleagues. The only place where you can learn from our unrivalled experience, while helping our global clients achieve high performance. If this is your idea of a typical working day, then Accenture is the place to be.

It all starts at Boot Camp. It's 48 hours that will stimulate your mind and enhance your career prospects. You'll spend time with other students, top Accenture Consultants and special guests. An inspirational two days

packed with intellectual challenges and activities designed to let you discover what it really means to be a high performer in business. We can't tell you everything about Boot Camp, but expect a fast-paced, exhilarating

and intense learning experience. It could be your toughest test yet, which is exactly what will make it your biggest opportunity.

Find out more and apply online.

Visit [accenture.com/bootcamp](https://www.accenture.com/bootcamp)

• Consulting • Technology • Outsourcing

High performance. Delivered.

Example 4.5 Find in each of the following cases a function

$$\Phi(x, y) = \int_{\mathcal{K}} \mathbf{V}(\tilde{\mathbf{x}}) \cdot d\tilde{\mathbf{x}},$$

to the given vector field $\mathbf{V} : A \rightarrow \mathbb{R}^2$, where \mathcal{K} is the broken line which runs from $(0, 0)$ over $(x, 0)$ to (x, y) . Check if Φ is defined in all of A , and compute finally the gradient $\nabla\Phi$.

1) The vector field $\mathbf{V}(x, y) = (y^2 - 2xy, -x^2 + 2xy)$ is defined in $A = \mathbb{R}^2$.

2) The vector field $\mathbf{V}(x, y) = \left(\frac{1}{\sqrt{y^2 - x^2 + 1}}, x \right)$ is defined in

$$A = \{(x, y) \mid -\sqrt{1 + y^2} < x < \sqrt{1 + y^2}\}.$$

3) The vector field $\mathbf{V}(x, y) = \left(\frac{x}{\sqrt{1 - x^2 - y^2}}, \frac{y}{\sqrt{1 - x^2 - y^2}} \right)$ is defined in the disc A given by $x^2 + y^2 < 1$.

4) The vector field $\mathbf{V}(x, y) = \left(\frac{x - 1}{\sqrt{(x - 1)^2 + y^2}}, \frac{y}{\sqrt{(x - 1)^2 + y^2}} \right)$ in the set A given by $(x, y) \neq (1, 0)$.

5) The vector field $\mathbf{V}(x, y) = (\cos y, \cos x)$ is defined in $A = \mathbb{R}^2$.

6) The vector field $\mathbf{V}(x, y) = (\cos(xy), 0)$ is defined in $A = \mathbb{R}^2$.

7) The vector field $\mathbf{V}(x, y) = (x^2 + y^2, xy)$ is defined in $A = \mathbb{R}^2$.

8) The vector field $\mathbf{V}(x, y) = (x^2 + y^2, 2xy)$ is defined in $A = \mathbb{R}^2$.

A Tangential line integrals.

D Remove whenever possible total differentials. Integrate along a broken line. Finally, compute the gradient $\nabla\Phi$.

I 1) We get by inspection,

$$\begin{aligned} \Phi(x, y) &= \int_{\mathcal{K}} \mathbf{V}(\tilde{\mathbf{x}}) \cdot d\tilde{\mathbf{x}} = \int_{\mathcal{K}} \{(\tilde{y}^2 - 2\tilde{x}\tilde{y})d\tilde{x} + (-\tilde{x}^2 + 2\tilde{x}\tilde{y})d\tilde{y}\} \\ &= \int_{\mathcal{K}} d(\tilde{x}\tilde{y}^2 - \tilde{x}^2\tilde{y}) = xy^2 - x^2y \quad (= xy(y - x)). \end{aligned}$$

ALTERNATIVELY,

$$\Phi(x, y) = \int_{\mathcal{K}} \{(\tilde{y}^2 - 2\tilde{x}\tilde{y})d\tilde{x} + (-\tilde{x}^2 + 2\tilde{x}\tilde{y})d\tilde{y}\} = \int_0^x 0 dt + \int_0^y (-x^2 + 2xt)dt = xy^2 - x^2y.$$

Finally,

$$\nabla\Phi = (y^2 - 2xy, 2xy - x^2) = \mathbf{V}(x, y),$$

and Φ is defined in all of $A = \mathbb{R}^2$.

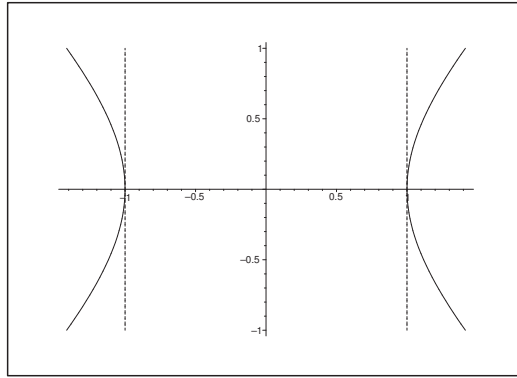

Figure 64: The domains of $\mathbf{V}(x, y)$ and $\Phi(x, y)$.

- 2) The domain A for $\mathbf{V}(x, y)$ lies between the two hyperbolic branches given by $x^2 - y^2 = 1$. The domain \tilde{A} of $\Phi(x, y)$ is smaller, in fact the points lying between the two vertical lines $x = \pm 1$, because we can only reach these by curves of the type \mathcal{K} . (The curve \mathcal{K} must never leave A , because we require that \mathbf{V} is defined).

We get for $(x, y) \in \tilde{A}$,

$$(5) \quad \Phi(x, y) = \int_0^x \frac{1}{\sqrt{1-t^2}} dt + \int_0^y x dt = \text{Arcsin } x + xy.$$

The function Φ is only defined in \tilde{A} . In this subset of A we get

$$\nabla \Phi(x, y) = \left(\frac{1}{\sqrt{1-x^2}} + y, x \right) \neq \mathbf{V}(x, y).$$

In particular, $\mathbf{V}(x, y)$ is not a gradient field.

REMARK. Formula (5) is a mindless insertion into one of the solution formulæ for this type of problems. It cannot be applied here because the *assumptions* of it are *not* fulfilled. \diamond

- 3) Here we get

$$\begin{aligned} \Phi(x, y) &= \int_{\mathcal{K}} \left\{ \frac{x}{\sqrt{1-x^2-y^2}} dx + \frac{y}{\sqrt{1-x^2-y^2}} dy \right\} \\ &= \int_{\mathcal{K}} d\left(-\sqrt{1-x^2-y^2}\right) = 1 - \sqrt{1-x^2-y^2}. \end{aligned}$$

ALTERNATIVELY we get for $x^2 + y^2 < 1$ by integration along the broken line that

$$\begin{aligned} \Phi(x, y) &= \int_0^x \frac{t}{\sqrt{1-t^2}} dt + \int_0^y \frac{t}{\sqrt{1-x^2-t^2}} dt = \left[-\sqrt{1-t^2}\right]_0^x + \left[-\sqrt{1-x^2-t^2}\right]_0^y \\ &= 1 - \sqrt{1-x^2} + \sqrt{1-x^2} - \sqrt{1-x^2-y^2} = 1 - \sqrt{1-x^2-y^2}. \end{aligned}$$

It follows immediately that

$$\nabla \Phi(x, y) = \left(\frac{x}{\sqrt{1-x^2-y^2}}, \frac{y}{\sqrt{1-x^2-y^2}} \right) = \mathbf{V}(x, y),$$

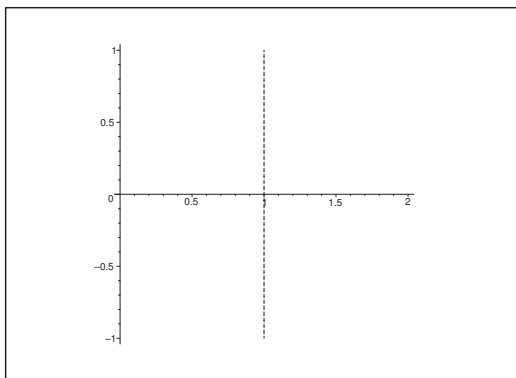

Figure 65: The domain \tilde{A} of Φ lies to the left of the dotted line $x = 1$.

and that Φ is defined in all of A .

4) In this case we have for any curve \mathcal{K} from $(0, 0)$ in A that

$$\begin{aligned} \Phi(x, y) &= \int_{\mathcal{K}} \left\{ \frac{x-1}{\sqrt{(x-1)^2 + y^2}} dx + \frac{y}{\sqrt{(x-1)^2 + y^2}} dy \right\} \\ &= \int_{\mathcal{K}} d\left(\sqrt{(x-1)^2 + y^2}\right) = \sqrt{(x-1)^2 + y^2} - 1. \end{aligned}$$

If we only integrate along curves \mathcal{K} of this type, then we can only reach points in

$$\tilde{A} = \{(x, y) \mid x < 1, y \in \mathbb{R}\}.$$

By integration along a broken line in this domain,

$$\begin{aligned} \Phi(x, y) &= \int_0^x \frac{t-1}{\sqrt{(t-1)^2 + 0^2}} dt + \int_0^y \frac{t}{\sqrt{(x-1)^2 + t^2}} dt \\ &= \int_0^x \frac{t-1}{|t-1|} dt + \left[\sqrt{(x-1)^2 + t^2} \right]_0^y \\ &= \int_0^x (-1) dt + \left[\sqrt{(x-1)^2 + y^2} - \sqrt{(x-1)^2} \right] \quad (\text{because } t < x < 1) \\ &= -x - |x-1| + \sqrt{(x-1)^2 + y^2} = x - (1-x) + \sqrt{(x-1)^2 + y^2} \\ &= \sqrt{(x-1)^2 + y^2} - 1. \end{aligned}$$

It follows that $\nabla\Phi = \mathbf{V}$ and that Φ can be extended to all of A .

5) When we integrate along the broken line

$$(0, 0) \longrightarrow (x, 0) \longrightarrow (x, y)$$

we get

$$\Phi(x, y) = \int_{\mathcal{K}} \mathbf{V} \cdot d\mathbf{x} = \int_0^x \cos 0 dt + \int_0^y \cos x dt = x + y \cos x,$$

which is defined in all of \mathbb{R}^2 . Here,

$$\nabla\Phi(x, y) = (1 - y \sin x, \cos x) \neq \mathbf{V}.$$

It is seen that \mathbf{V} is not a gradient field.

6) When we integrate along the broken line

$$(0, 0) \longrightarrow (x, 0) \longrightarrow (x, y)$$

we get in all of \mathbb{R}^2 ,

$$\Phi(x, y) = \int_{\mathcal{K}} \mathbf{V} \cdot d\mathbf{x} = \int_0^x \cos(t \cdot 0) dt + 0 = x,$$

where $\nabla\Phi = (1, 0) \neq \mathbf{V}$, so \mathbf{V} is not a gradient field.

7) When we integrate along the broken line

$$(0, 0) \longrightarrow (x, 0) \longrightarrow (x, y)$$

we get in all of \mathbb{R}^2 ,

$$\Phi(x, y) = \int_{\mathcal{K}} \mathbf{V} \cdot d\mathbf{x} = \int_0^x (t^2 + 0^2) dt + \int_0^y xt dt = x^3 + \frac{1}{2}xy^2,$$

Please click the advert



it's an **interesting** world

Get under the skin of it.

Graduate opportunities
Cheltenham | £24,945 + benefits

One of the UK's intelligence services, GCHQ's role is two-fold: to gather and analyse intelligence which helps shape Britain's response to global events, and, to provide technical advice for the protection of Government communication and information systems. In doing so, our specialists – in IT, internet, engineering, languages, information assurance, mathematics and intelligence – get well beneath the surface of global affairs. If you thought the world was an interesting place, you really ought to explore our world of work.

www.careersinbritishintelligence.co.uk

Applicants must be British citizens. GCHQ values diversity and welcomes applicants from all sections of the community. We want our workforce to reflect the diversity of our work.



where

$$\nabla\Phi = \left(3x^2 + \frac{1}{2}y^2, xy\right) \neq \mathbf{V}(x, y).$$

It follows that \mathbf{V} is not a gradient field.

8) When we integrate along the broken line

$$(0, 0) \longrightarrow (x, 0) \longrightarrow (x, y)$$

we get in \mathbb{R}^2

$$\Phi(x, y) = \int_{\mathcal{K}} \mathbf{V} \cdot d\mathbf{x} = \int_0^x (t^2 + 0^2) dt + \int_0^y 2xt dt = \frac{x^3}{3} + xy^2,$$

where

$$\nabla\Phi = (x^2 + y^2, 2xy) = \mathbf{V}(x, y).$$

In this case $\mathbf{V}(x, y)$ is a gradient field.

Example 4.6 Compute in each of the following cases the tangential line integral of the given vector field $\mathbf{V} : \mathbb{R}^2 \rightarrow \mathbb{R}^2$ along the described curve \mathcal{K} .

- 1) The vector field $\mathbf{V}(x, y) = \nabla\left(\frac{1}{2}x^2 + xy - \frac{1}{2}y^2\right)$ along the ellipse \mathcal{K} of centrum $(0, 0)$ and half axes a, b , in the positive orientation of the plane.
- 2) The vector field $\mathbf{V}(x, y) = \nabla(x^4 + \ln(1 + y))$ along the arc of the parabola \mathcal{K} given by $y = x^2$, $x \in [-1, 3]$.
- 3) The vector field $\mathbf{V}(x, y) = \nabla(x + 2y - \exp(xy))$ along the broken line \mathcal{K} , which goes from $(2, 0)$ over $(1, 2)$ to $(0, 1)$.

A Line integral of a gradient field.

D As $\mathbf{V}(x, y) = \nabla F$, the tangential line integral is only depending on the initial point and the end point,

$$\int_{\mathcal{K}} \mathbf{V} \cdot d\mathbf{s} = F(\mathbf{x}_s) - F(\mathbf{x}_b).$$

I 1) The ellipse is a closed curve, so

$$\int_{\mathcal{K}} \mathbf{V} \cdot d\mathbf{x} = 0.$$

2) The initial point is $(-1, 1)$, and the end point is $(3, 9)$, hence

$$\int_{\mathcal{K}} \mathbf{V} \cdot d\mathbf{x} = [x^4 + \ln(1 + y)]_{(-1,1)}^{(3,9)} = 81 + \ln 10 - 1 - \ln 2 = 80 + \ln 5.$$

3) The initial point is $(2, 0)$, and the end point is $(0, 1)$, thus

$$\int_{\mathcal{K}} \mathbf{V} \cdot d\mathbf{x} = [x + 2y - \exp(xy)]_{(2,0)}^{(0,1)} = 0 + 2 - 1 - 2 - 0 + 1 = 0.$$

Example 4.7 Compute in each of the following cases the tangential line integral of the given vector field $\mathbf{V} : \mathbb{R}^3 \rightarrow \mathbb{R}^3$ along the described curve \mathcal{K} .

1) The vector field $\nabla(x^2 + yz)$ along the curve \mathcal{K} , given by

$$\mathbf{r}(t) = (\cos t, \sin t, \sin(2t)), \quad t \in [0, 2\pi].$$

2) The vector field $\nabla(\cos(xyz))$ along the line segment \mathcal{K} from $(\pi, \frac{1}{2}, 0)$ to $(\frac{1}{2}, \pi, -1)$.

3) The vector field $\nabla(\exp x + \ln(1 + |yz|))$ along the broken line \mathcal{K} , which goes from $(0, 1, 1)$, via $(\pi, -3, 2)$ to $(1, \sqrt{3}, -\sqrt{3})$.

A Tangential line integrals of gradient fields.

D Use that

$$\int_{\mathcal{K}} \nabla F \cdot d\mathbf{x} = F(\text{end point}) - F(\text{initial point}),$$

is independent of the path of integration.

Since the absolute value occurs in **Example 4.7.3**, we shall here be very careful.

I 1) As \mathcal{K} is a closed curve (i.e. the initial point $(1, 0, 0)$ is equal to the end point), it follows that

$$\int_{\mathcal{K}} \mathbf{V} \cdot d\mathbf{x} = 0.$$

2) Since $F(x, y, z) = \cos(xyz)$, and the initial point and the end point are given, we have

$$\int_{\mathcal{K}} \mathbf{V} \cdot d\mathbf{x} = \cos\left(\frac{1}{2} \cdot \pi \cdot (-1)\right) - \cos\left(\pi \cdot \frac{1}{2} \cdot 0\right) = -1.$$

3) First notice that

$$F(x, y, z) = \begin{cases} \exp x + \ln(1 + yz) & \text{for } yz > 0, \\ \exp x + \ln(1 - yz) & \text{for } yz < 0, \end{cases}$$

so we must be very careful, whenever the curve \mathcal{K} intersects one of the planes $y = 0$ or $z = 0$. In case of the first curves this can occur, because the parametric description is

$$t(0, 1, 1) + (1-t)(\pi, -3, 2) = ((1-t)\pi, 4t-3, 2-t), \quad t \in [0, 1],$$

and the same is true for the second curve, because it has the parametric description

$$t(\pi, -3, 2) + (1-t)(1, \sqrt{3}, -\sqrt{3}) = (1+t(\pi-1), \sqrt{3}-t(3+\sqrt{3}), -\sqrt{3}+t(2+\sqrt{3})),$$

for $t \in [0, 1]$.

The former curve intersects the plane $y = 0$ for $t = \frac{3}{4}$, and the latter curve intersects both the plane $y = 0$ and the plane $z = 0$. The point is, however, that in everyone of these intersection points the dubious term $\ln(1 + |xy|) = 0$, so they are of no importance. Hence we can conclude that

$$\begin{aligned} \int_{\mathcal{K}} \mathbf{V} \cdot d\mathbf{x} &= [\exp x + \ln(1 + |yz|)]_{(0,1,1)}^{(1,\sqrt{3},-\sqrt{3})} \\ &= e + \ln 4 - 1 - \ln 2 = e - 1 + \ln 2. \end{aligned}$$

REMARK. Always be very careful when either the absolute value or the square root occur. One should at least give a note on them. \diamond

Please click the advert

Brain power

By 2020, wind could provide one-tenth of our planet's electricity needs. Already today, SKF's innovative know-how is crucial to running a large proportion of the world's wind turbines.

Up to 25 % of the generating costs relate to maintenance. These can be reduced dramatically thanks to our systems for on-line condition monitoring and automatic lubrication. We help make it more economical to create cleaner, cheaper energy out of thin air.

By sharing our experience, expertise, and creativity, industries can boost performance beyond expectations. Therefore we need the best employees who can meet this challenge!

The Power of Knowledge Engineering

Plug into The Power of Knowledge Engineering.
Visit us at www.skf.com/knowledge

SKF

Download free books at BookBooN.com

Example 4.8 Given the vector field

$$\mathbf{V}(x, y) = \left(\frac{2y}{2x + y}, \frac{y}{2x + y} + \ln(2x + y) \right).$$

1. Sketch the domain of \mathbf{V} , and explain why \mathbf{V} is a gradient field.
2. Find every integral of \mathbf{V} .

Let \mathcal{K} be the curve given by

$$(x, y) = (2t^2, t), \quad 1 \leq t \leq 2.$$

3. Compute the value of the tangential line integral

$$\int_{\mathcal{K}} \mathbf{V} \cdot \mathbf{t} \, ds.$$

Let F be the integral of \mathbf{V} , for which $F(1, 1) = 0$.

4. Find an equation of the tangent at the en point $(1, 1)$ of that level curve for F , which goes through the point $(1, 1)$.
- A** Gradient field, integrals, tangential line integral, level curve.
D Follow the guidelines.

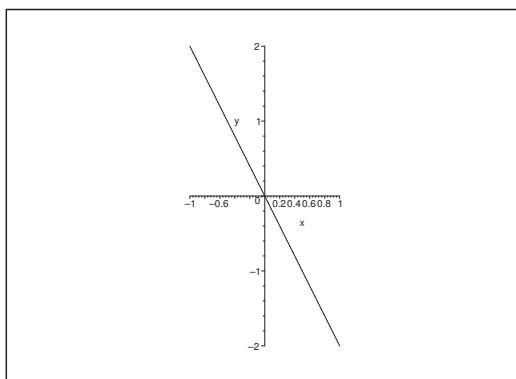

Figure 66: The domain is the open half plane above the oblique line.

I 1) Clearly, $\mathbf{V}(x, y)$ is defined in the domain where $2x + y > 0$, cf. the figure.

As

$$\frac{\partial V_1}{\partial y} = \frac{2}{2x + y} - \frac{2y}{(2x + y)^2},$$

and

$$\frac{\partial V_2}{\partial x} = -\frac{2y}{(2x + y)^2} + \frac{2}{2x + y} = \frac{\partial V_1}{\partial y},$$

it follows that $V_1 dx + V_2 dy$ is a closed differential form. Since the domain is simply connected, the differential form is even exact, and \mathbf{V} is a gradient field.

2) Since

$$F_1(x, y) = \int \frac{2y}{2x+y} dx = y \int \frac{2 dx}{2x+y} = y \ln(2x+y), \quad 2x+y > 0,$$

where

$$\nabla F_1 = \left(\frac{2y}{2x+y}, \frac{y}{2x+y} + \ln(2x+y) \right) = \mathbf{V}(x, y),$$

all integrals are given by

$$F(x, y) = y \ln(2x+y) + C, \quad C \in \mathbb{R}.$$

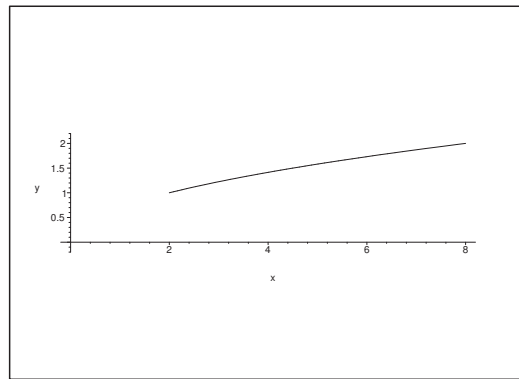

Figure 67: The curve \mathcal{K} .

3) We get by the reduction theorem for tangential line integrals that

$$\begin{aligned} \int_{\mathcal{K}} \mathbf{V} \cdot \mathbf{t} ds &= \int_1^2 \mathbf{V}(\mathbf{r}(t)) \cdot \mathbf{r}'(t) dt \\ &= \int_1^2 \left(\frac{2t}{4t^2+t}, \frac{t}{4t^2+t} + \ln(4t^2+t) \right) \cdot (4t, 1) dt \\ &= \int_1^2 \left\{ \frac{8t}{4t+1} + \frac{1}{4t+1} + \ln(4t^2+t) \right\} dt \\ &= \int_1^2 \left\{ 2 - \frac{1}{4t+1} + \ln t + \ln(4t+1) \right\} dt \\ &= 2 - \frac{1}{4} [\ln(4t+1)]_1^2 + [t \ln t - t]_1^2 + [t \ln(4t+1)]_1^2 - \int_1^2 \frac{4t}{4t+1} dt \\ &= 2 - \frac{1}{4} [\ln(4t+1)]_1^2 + 2 \ln 2 - 1 + 2 \ln 9 - \ln 5 - 1 + \frac{1}{4} [\ln(4t+1)]_1^2 \\ &= 2 \ln 2 + 4 \ln 3 - \ln 5 = \ln \frac{324}{5}. \end{aligned}$$

4) It follows from $F(1, 1) = \ln 3 + C = 0$ that $C = -\ln 3$, so

$$F(x, y) = y \ln(2x+y) - \ln 3.$$

However, we shall not need the exact value of $C = -\ln 3$ in the following.

The normal of the level curve is $\nabla F = \mathbf{V}$, hence

$$\mathbf{V}(1, 1) = \left(\frac{2}{3}, \frac{1}{3} + \ln 3 \right),$$

and the direction of the tangent is e.g.

$$\mathbf{v} = \left(\frac{1}{3} + \ln 3, -\frac{2}{3} \right),$$

and we get a parametric description of the tangent,

$$(x(t), y(t)) = (1, 1) + t \left(\frac{1}{3} + \ln 3, -\frac{2}{3} \right), \quad t \in \mathbb{R}.$$

If we instead want an equation of the tangent, then one possibility is given by

$$0 = \mathbf{V} \cdot (x - 1, y - 1) = \frac{2}{3}x + \left(\frac{1}{3} + \ln 3 \right)y - 1 - \ln 3.$$

Trust and responsibility

NNE and Pharmaplan have joined forces to create NNE Pharmaplan, the world's leading engineering and consultancy company focused entirely on the pharma and biotech industries.

Inés Aréizaga Esteva (Spain), 25 years old
Education: Chemical Engineer

– You have to be proactive and open-minded as a newcomer and make it clear to your colleagues what you are able to cope. The pharmaceutical field is new to me. But busy as they are, most of my colleagues find the time to teach me, and they also trust me. Even though it was a bit hard at first, I can feel over time that I am beginning to be taken seriously and that my contribution is appreciated.

Please click the advert



NNE Pharmaplan is the world's leading engineering and consultancy company focused entirely on the pharma and biotech industries. We employ more than 1500 people worldwide and offer global reach and local knowledge along with our all-encompassing list of services.
nnepharmaplan.com

nne pharmaplan[®]